

BRAINY 24-SW BRAINY 24 +

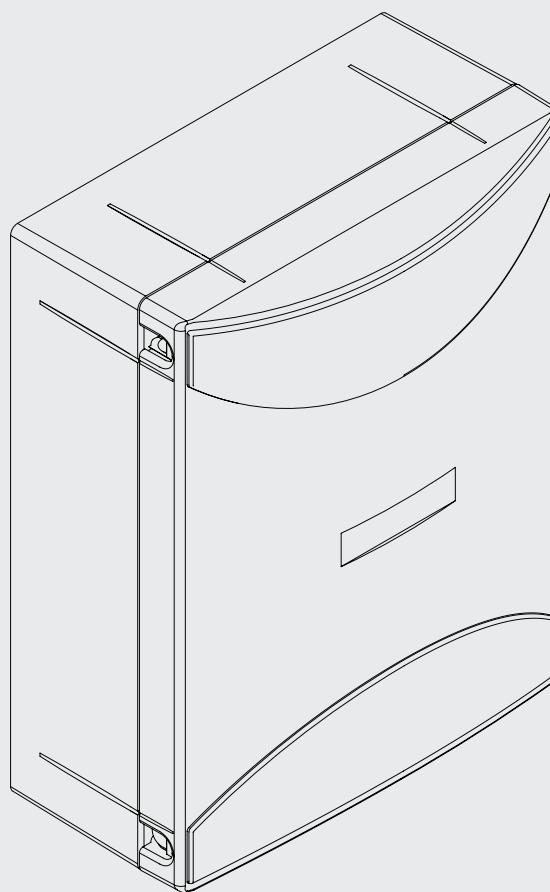

BENINCA[®]
TECHNOLOGY TO OPEN



BRAINY 24-SW

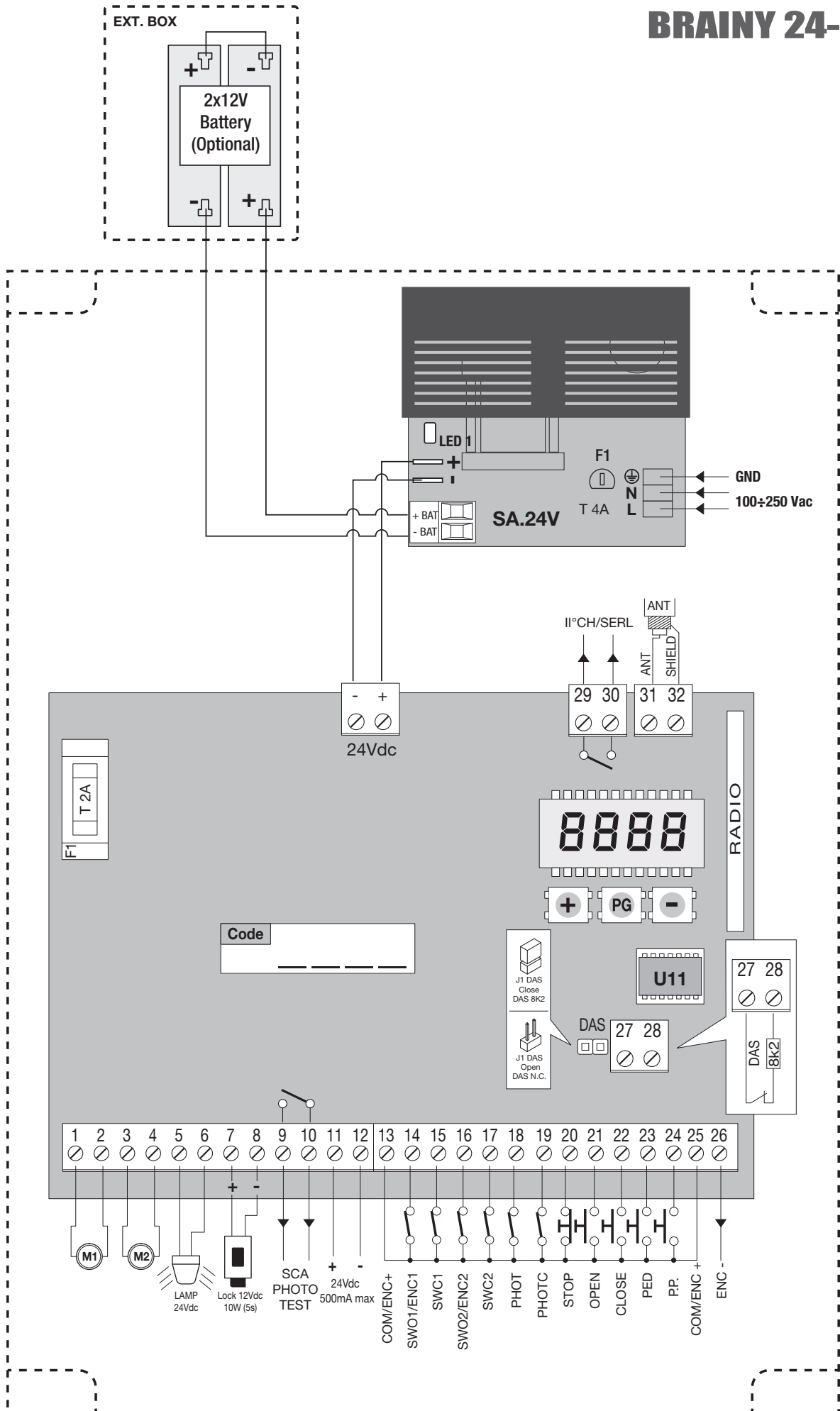

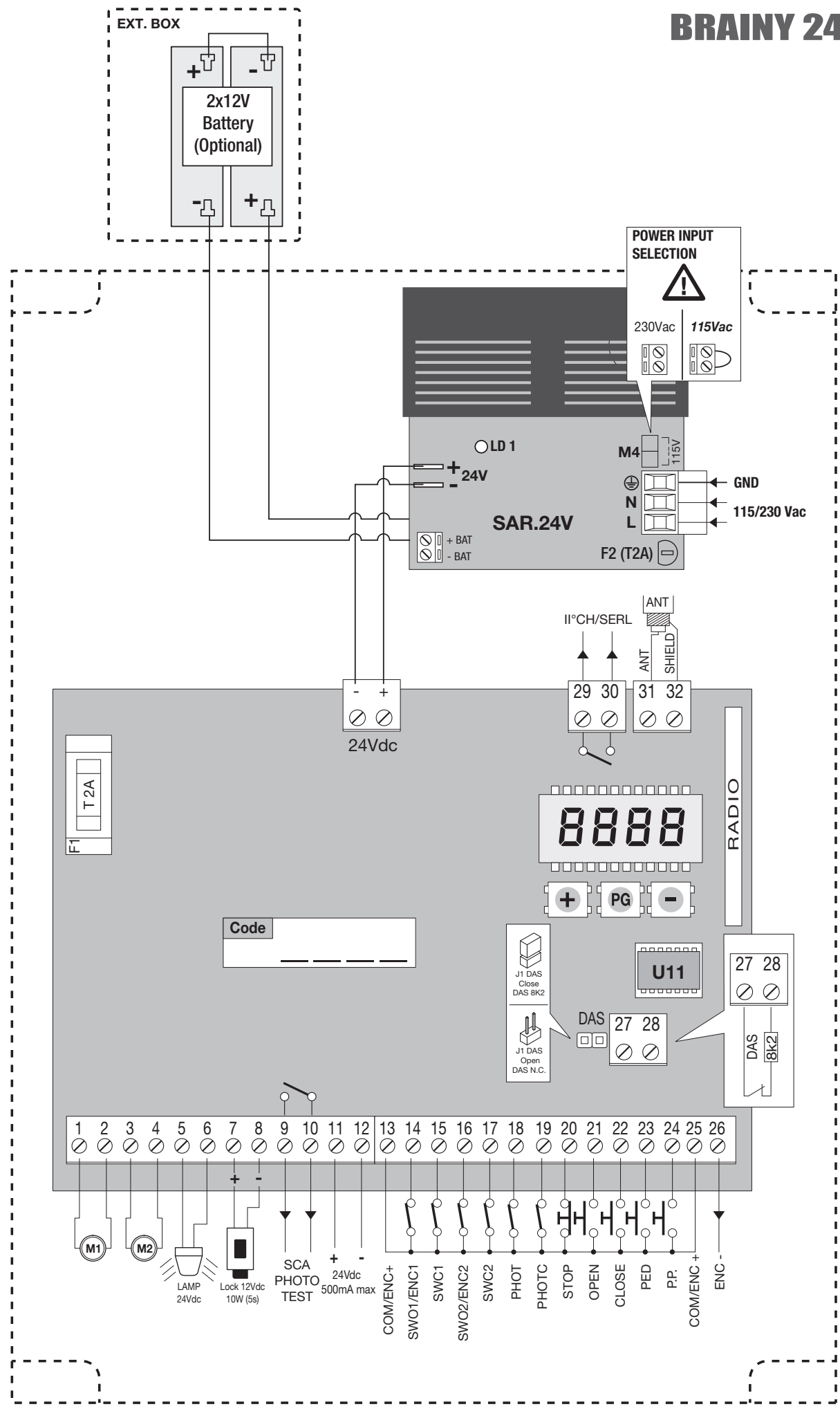

3

**Collegamento ENCODER
ENCODER WIRING**

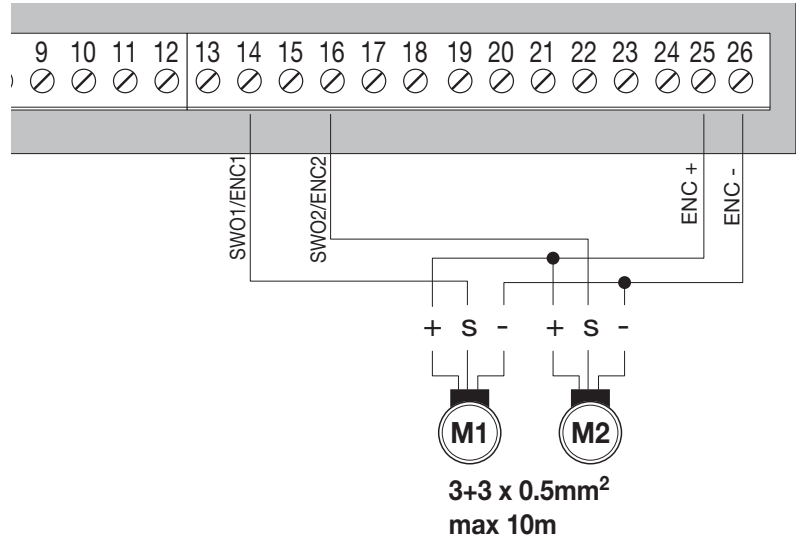

4

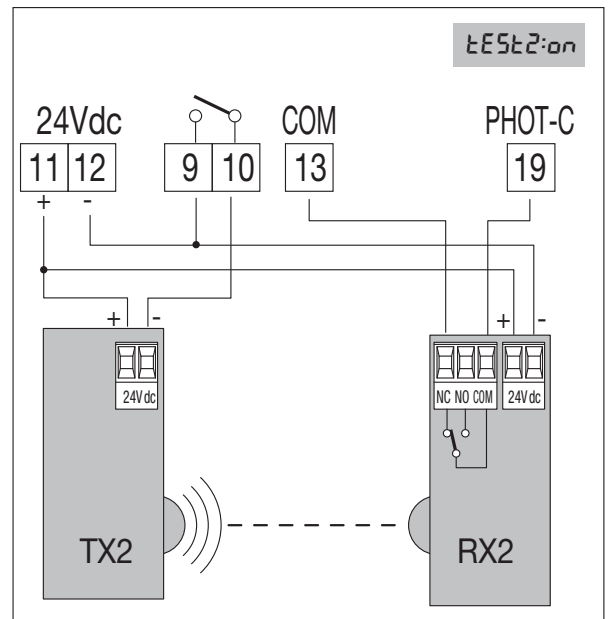
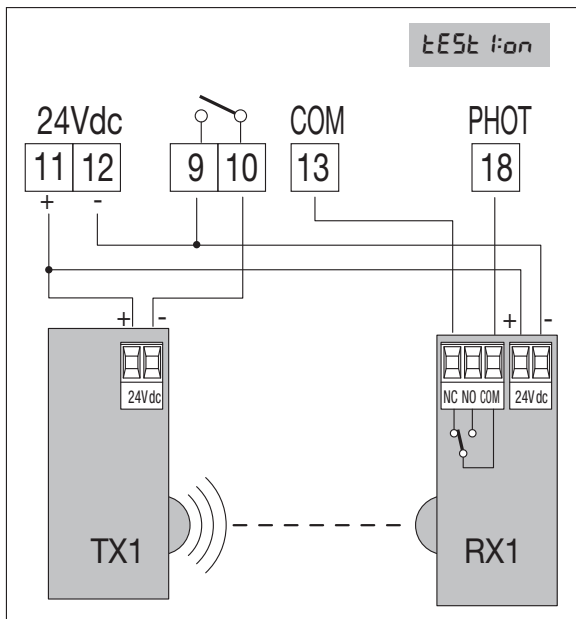

5

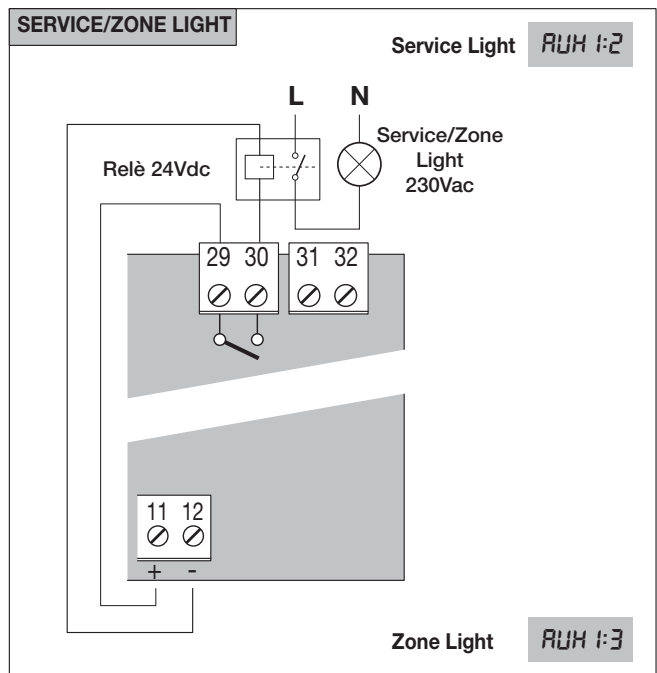
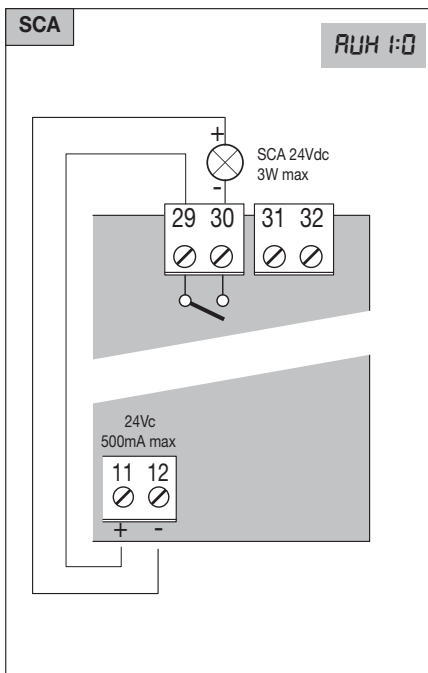

Schema menu di programmazione - Menu programming layout
 Diagramm Programmiermenü - Menu de programmation
 Menú de la carta de programación - Układ menu programowania

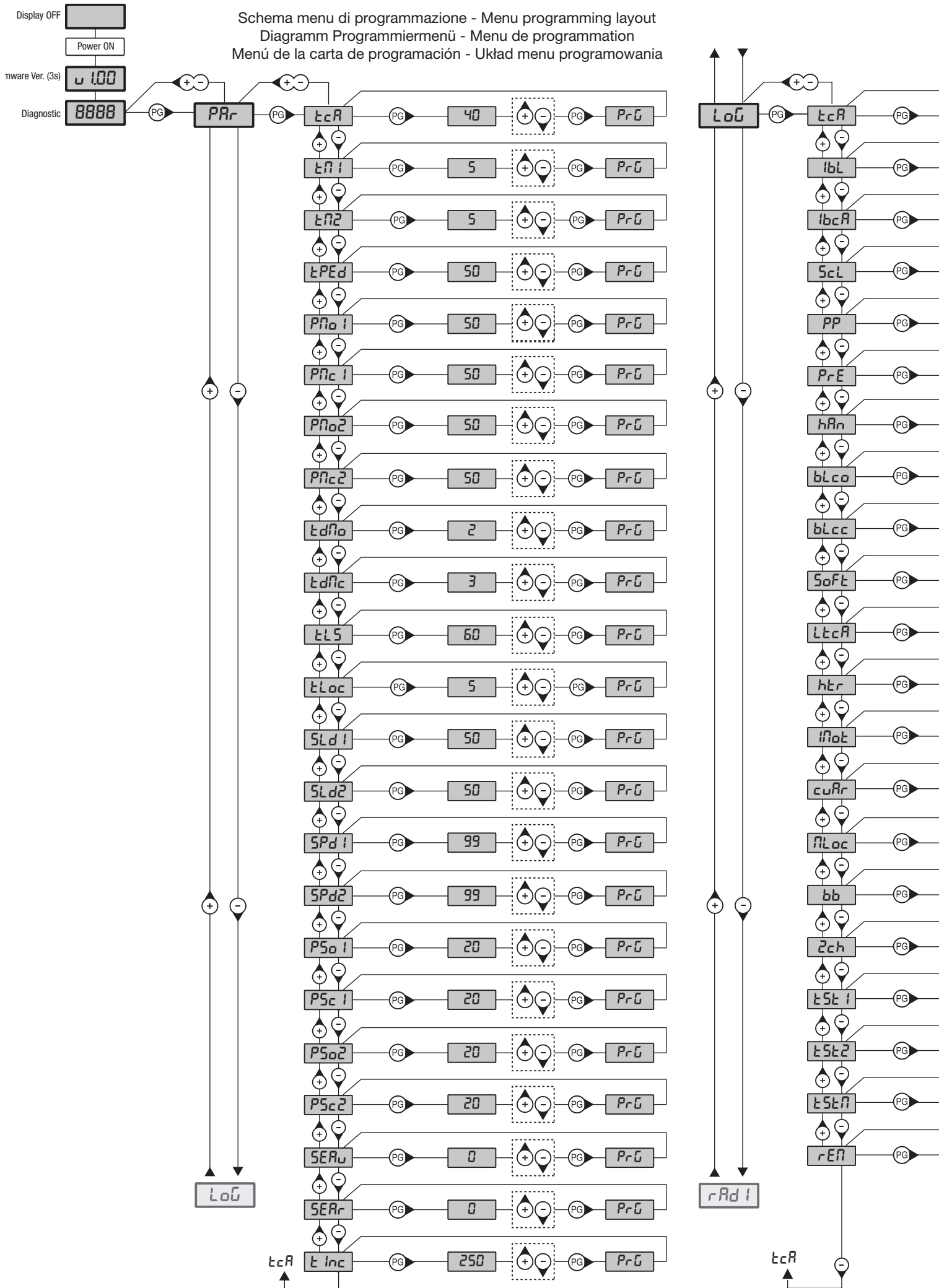

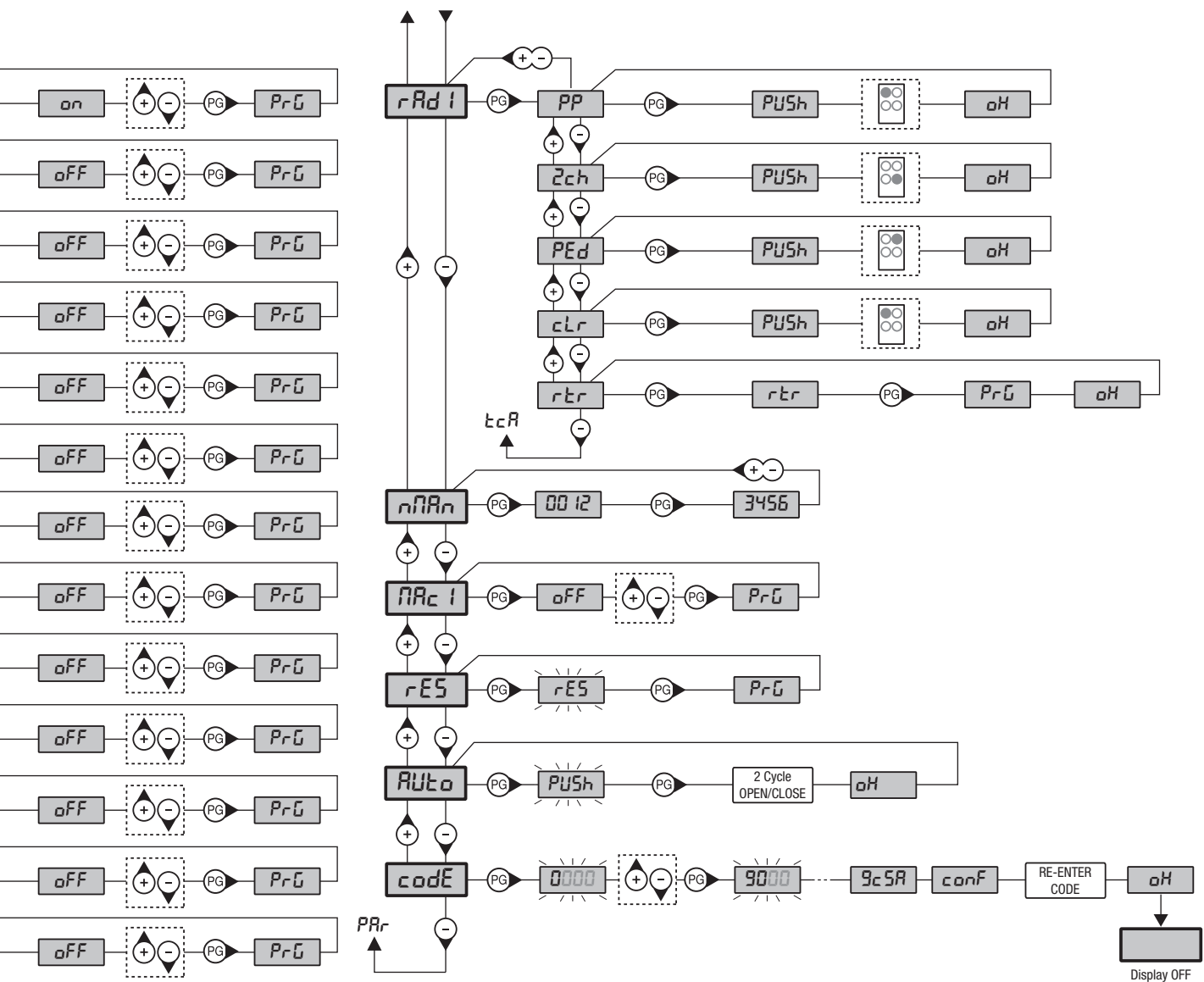

Legenda

	Premere il tasto (-) / Press key (-) / Die Taste (-) drücken Appuyez sur la touche (-) / Presionar la tecla (-) / Wcisnąć przycisk (-)
	Premere il tasto (+) / Press key (+) / Die Taste (+) drücken Appuyez sur la touche (+) / Presionar la tecla (+) / Wcisnąć przycisk (+)
	Premere il tasto (PG) / Press key (PG) / Die Taste (PG) drücken Appuyez sur la touche (PG) / Presionar la tecla (PG) / Wcisnąć przycisk (PG)
	Premere simultaneamente (+) e (-) / Press simultaneously keys (+) and (-) Gleichzeitig (+) und (-) drücken / Presser simultanément (+) et (-) Presionar simultáneamente (+) y (-) / Naciskać jednocześnie (+) i (-)
	Selezionare il valore desiderato con i pulsanti (+) e (-) Increase/decrease the value with keys (+) and (-) Mit den Tasten (+) und (-) kann man eingerichtete Werte ändern Régler la valeur désirée avec les touches (+) et (-) Establecer con las teclas (+) y (-) el valor deseado Nastawia przyciskami (+) i (-) obraną wartość
	Selezionare il pulsante del trasmettitore da associare alla funzione Press the transmitter key, which is to be assigned to function Taste des Sendegeräts drücken, dem diese Funktion zugeteilt werden soll. Appuyer sur la touche du transmetteur qu'e l'on désire affecter à cette fonction. Presionar la tecla del transmisor que se desea asignar a esta función. Wcisnąć przycisk nadajnika, który zamierza się skojarzyć z tą funkcją.

GENERAL INFORMATIONS

The product shall not be used for purposes or in ways other than those for which the product is intended for and as described in this manual.



Incorrect uses can damage the product and cause injuries and damages.

The company shall not be deemed responsible for the non-compliance with a good manufacture technique of gates as well as for any deformation, which might occur during use.

Keep this manual for further use.

INSTALLER GUIDE

This manual has been especially written to be use by qualified fitters.

Installation must be carried out by qualified personnel (professional installer, according to EN 12635), in compliance with Good Practice and current code.

Make sure that the structure of the gate is suitable for automation.

The installer must supply all information on the automatic, manual and emergency operation of the automatic system and supply the end user with instructions for use.

**GENERAL WARNINGS**

Packaging must be kept out of reach of children, as it can be hazardous.

For disposal, packaging must be divided the various types of waste (e.g. carton board, polystyrene) in compliance with regulations in force.

Do not allow children to play with the fixed control devices of the product.

Keep the remote controls out of reach of children.

This product is not to be used by persons (including children) with reduced physical, sensory or mental capacity, or who are unfamiliar with such equipment, unless under the supervision of or following training by persons responsible for their safety. Apply all safety devices (photocells, safety edges, etc.) required to keep the area free of impact, crushing, dragging and shearing hazard.

Bear in mind the standards and directives in force, Good Practice criteria, intended use, the installation environment, the operating logic of the system and forces generated by the automated system. Installation must be carried out using safety devices and controls that meet standards EN 12978 and EN 12453.

Only use original accessories and spare parts, use of non-original spare parts will cause the warranty planned to cover the products to become null and void.

All the mechanical and electrical parts composing automation must meet the requirements of the standards in force and outlined by CE marking.

**ELECTRICAL SAFETY**

An omnipolar switch/section switch with remote contact opening equal to, or higher than 3mm must be provided on the power supply mains.

Make sure that before wiring an adequate differential switch and an overcurrent protection is provided.

Pursuant to safety regulations in force, some types of installation require that the gate connection be earthed. During installation, maintenance and repair, cut off power supply before accessing to live parts.

Also disconnect buffer batteries, if any are connected.

The electrical installation and the operating logic must comply with the regulations in force. The leads fed with different voltages must be physically separate, or they must be suitably insulated with additional insulation of at least 1 mm. The leads must be secured with an additional fixture near the terminals.

During installation, maintenance and repair, interrupt the power supply before opening the lid to access the electrical parts

Check all the connections again before switching on the power.

The unused N.C. inputs must be bridged.

**WASTE DISPOSAL**

As indicated by the symbol shown, it is forbidden to dispose this product as normal urban waste as some parts might be harmful for environment and human health, if they are disposed of incorrectly.

Therefore, the device should be disposed in special collection platforms or given back to the reseller if a new and similar device is purchased.

An incorrect disposal of the device will result in fines applied to the user, as provided for by regulations in force.



Descriptions and figures in this manual are not binding. While leaving the essential characteristics of the product unchanged, the manufacturer reserves the right to modify the same under the technical, design or commercial point of view without necessarily update this manual.

BRAINY 24-SW/BRAINY 24+ CONTROL UNIT

AUTOSET FUNCTION

IMPORTANT: The control unit is equipped with the AutoSet function to automatically set the main functioning values based on the type of installation.

The AUTOSET function must be repeated at every function parameter change or upon change of automation conditions. See the AUTO menu for further information.

WIRE DIAGRAM

Wire connections shown in Fig. 1/2 are described hereunder:

SA.24V (BRAINY 24-SW)		
Terminal	Function	Description
L-N-GND	Power supply	Mains input 100÷250Vac 50/60Hz
+ -	Output 24Vdc	Controller BRAINY 24 power supply output 24 Vdc
+BAT-	Batteries	Clamp input for connection of back-up batteries (accessory).

SAR.24V (BRAINY 24+)		
Terminal	Function	Description
L-N-GND	Power supply	Power supply input (115V ± 10% or 230V ± 10%) selectable via terminal M4
M4	Power supply selection	WARNING: to use the central unit with 115V power supply, it is necessary to jumper this terminal.
+ 24V -	Output 24Vdc	Controller BRAINY 24 power supply output 24 Vdc
+BAT-	Batteries	Clamp input for connection of back-up batteries (accessory).

BRAINY 24-SW/BRAINY24+		
Terminal No.	Function	Description
1-2	Motor 1	Connection, motor 1: 24VDC 5A max
3-4	Motor 2	Connection, motor 2: 24VDC 5A max
5-6	Flashing light	Connection, flashing light 24VDC 15W max.
7-8	Lock	Output, 12Vdc/10W power supply for electric lock (7:+12V, 8:0V)
9-10	SCA/ PHOTO TEST	Contact free from N.O. Voltage, may be configured as open gate indicator or photocell test. For use as "Open gate indicator" the TEST1 and TEST2 logics must be OFF. For use as photocell test it is sufficient to activate one or both TEST logics and connect the photocells as indicated in Fig.3.
11-12	24 Vdc	Output, accessory power supply, 24VAC/0.5A max. Make sure the devices are correctly connected (i.e. 11:+24Vdc / 12:-0Vdc).
13	COM/ENC+	Common for limit switch and all the command inlets or encoder power supply.
14	SWO1/ENC1	Motor 1 OPEN limit switch input (N.C. contact) or Motor 1 Encoder connection.
15	SWC1	Motor 1 CLOSE limit switch input, (N.C. Contact)
16	SWO2/ENC2	Motor 2 OPEN limit switch input, (N.C. Contact) or Motor 2 Encoder connection.
17	SWC2	Motor 2 CLOSE limit switch input, (N.C. Contact)
18	PHOT	Input, photocell activated in both opening and closing phases
19	PHOT C	Input, photocell activated in closing phase only (Normally closed contact)
20	STOP	Input, STOP push-button (Normally closed contact)
21	OPEN	Input, OPEN push-button (Normally open contact). It is possible to connect a timer for opening in time slots.
22	CLOSE	Input, CLOSE push-button (Normally open contact)
23	PED	Pedestrian button input (N.O. Contact), controls the motor 1 opening, see TPED parameter.
24	Step-by-Step	Input, step-by-step push button (Normally open contact)
25	COM/ENC+	Common for Limit switch and all the command inputs or encoder power supply.
26	ENC-	Input for GND Encoder connection (see Fig.3).

27-28	SENSITIVE EDGE (DAS)	Input, sensitive edge contact Resistive edge: "DAS" Jumper closed Mechanical edge: "DAS" Jumper open When the edge is activated, the gate movement is stopped and reversed for about 3s.
29-30	II°CH/SERL	N.O. Contact free from Voltage, may be configured as second radio channel or service light. For use as second radio channel the 2CH logic must be ON. For use as courtesy light the 2CH logic must be OFF.
31-32	Antenna	Connection to the built-in radio receiver card (30-signal/31-screen).
+ / -	24Vdc	Input, 24VDC power supply.
U11	CONFIGURATION MEMORY	Extractable Eprom Memory. Contains all the control unit configurations (logics, parameters, etc.), including the radiotransmitters. In case of faults it is possible to extract Eprom and insert it into a different control unit, avoiding reprogramming.
The control unit is equipped with an built-in radio module for the reception of variable code controls, with ARC (Advanced Rolling-Code) or fixed code, 433.92 MHz frequency.		

ENCODER WIRING

In case the motor is with Encoder and one wished to connect it to the control unit, carry out the connections indicated in Fig.3, in this case the SWO1 and SWO2 inputs may not be used as Limit switch inputs.
It is not possible to use the Encoder and the closure Limit switch simultaneously.
Leave SWC1 and SWC2 shorted.

ARC COMPATIBLE CONTROL UNIT

IMPORTANT, PLEASE READ CAREFULLY:

The radio receiver in this product is compatible with the new ARC (Advanced Rolling Code) transmitters which, thanks to 128-bit encryption ensure superior copy-security.

Storing new ARC transmitters is quite similar to that of normal rolling code transmitters with HCS coding, but be aware that:

- 1) ARC transmitters and Rolling Code HCS can not be stored in a single receiver.
- 2) The first transmitter memorized determines the type of transmitters to be used later. If the first transmitter memorized is ARC, you can not store Rolling code HCS transmitters, and vice versa.
- 3) Fixed code transmitters may only be used in conjunction with Rolling code HCS transmitters, bringing the logic CVAR OFF. They are, therefore, not usable in combination with the ARC transmitters. If the first rolling code transmitter stored is an ARC CVAR the logic is inoperative.
- 4) If you want to change the type of transmitters it is necessary to proceed with a receiver reset.

TO CHECK CONNECTIONS

- 1) Cut-off power supply.
- 2) Manually release the wings, move them to approx. half-stroke and lock them again.
- 3) Reset power supply.
- 4) Send a step-by-step control signal by pressing the <-> push-button.
- 5) **The leaves must move in OPENING.**
In case this does not happen, it is sufficient to invert among them the motor run wires. (1<>2 for M1 motor, and 3<>4 for M2 motor) and, if used, the relative Limit switch inputs (14<>15 for M1 motor, and 16<>17 for M2 motor).

PROGRAMMING

The programming of the various functions of the control unit is carried out using the LCD display on the control unit and setting the desired values in the programming menus described below.

The parameters menu allows you to assign a numerical value to a function, in the same way as a regulating trimmer.

The logic menu allows you to activate or deactivate a function, in the same way as setting a dip-switch.

Other special functions follow the parameters and logic menus and may vary depending on the type of control unit or the software release.

TO ACCESS PROGRAMMING:

- 1 - Press the button <PG>, the display goes to the first menu, Parameters "PAR".
- 2 - With the <+> or <-> button, select the menu you want (PAR>LOG>RAD>NMAN>MACI>RES>AUTO>CODE).
- 3- Press the button <PG>, the display shows the first function available on the menu.
- 4 - With the <+> or <-> button, select the function you want.
- 5 - Press the button <PG>, the display shows the value currently set for the function selected.
- 6 - With the <+> or <-> button, select the value you intend to assign to the function.
- 7 - Press the button <PG>, the display shows the signal "PRG" which indicates that programming has been completed.

NOTES:

Simultaneously pressing <+> and <-> from inside a function menu allows you to return to the previous menu without making any changes. Hold down the <+> key or the <-> key to accelerate the increase/decrease of the values.

After waiting 120s the control unit quits programming mode and switches off the display.

When the board is switched on, the software version is displayed for around 5 sec

Hold down the <+> key or the <-> key to accelerate the increase/decrease of the values.

PARAMETERS, LOGIC AND SPECIAL FUNCTIONS

The tables below describe the individual functions available in the control unit.

PARAMETERS (PR)			
MENU	FUNCTION	MIN-MAX-(Default)	MEMO
tCA	Automatic closing time. Active only with logic "TCA"=ON. At the end of the set time the control unit orders a closing manoeuvre.	1-240-(40s)	
tN1	Operating time, motor 1. The operating time is adjusted at normal speed during motor 1 opening and closing phases. See Paragraph "Adjustment of the gate leaf speed". By setting the value to 0, the operation is performed with around 2 seconds of pick-up and then the movement is carried on at reduced speed for the entire stroke. In the motors with encoder, the value is expressed in percentage. In motors without encoder the value is expressed in seconds.	0-99-(5)	
tN2	Operating time, motor 2. The operating time is adjusted at normal speed during motor 2 opening and closing phases. See Paragraph "Adjustment of the gate leaf speed". By setting the value to 0, the operation is performed with around 2 seconds of pick-up and then the movement is carried on at reduced speed for the entire stroke. In the motors with encoder, the value is expressed in percentage. In motors without encoder the value is expressed in seconds.	0-99-(5)	
tPEd	Adjusts the motor 1 opening percentage (pedestrian function). With Encoder equipped motors the value is expressed in a percentage (99% mean complete opening cycle). With the motors without Encoder or electrical Limit switch, the value is expressed in seconds. In the motors with encoder, the value is expressed in percentage. In motors without encoder the value is expressed in seconds.	1-99 (50)	
PNo1	The anti-crash device* (amperometric sensor) operation is adjusted in the opening phase, at normal speed - Motor 1.	1-99-(50%)**	
Pnc1	The anti-crash device* (amperometric sensor) operation is adjusted in the closing phase, at normal speed - Motor 1.	1-99-(50%)**	
PNo2	The anti-crash device* (amperometric sensor) operation is adjusted in the opening phase, at normal speed - Motor 2.	1-99-(50%)**	
Pnc2	The anti-crash device* (amperometric sensor) operation is adjusted in the closing phase, at normal speed - Motor 2.	1-99-(50%)**	
tdNo	Mot.2 opening delay time. Regulates the delay time of motor 2 on opening with respect to motor 1	0-15-(2s)	
tdNc	Mot.1 closing delay time Regulates the delay time of motor 1 on closing with respect to motor 2	0-40-(3s)	
tLS	SERL contact activation time (Service light) 29/30 terminals. At each manoeuvre the contact closes for the set time. See Figure 5 connection scheme.	1-240-(60s)	
tLoc	Electric lock activation time. The value is expressed in 1/10s (0=0s - 50=5s)	0-50 (5=0,5s)	
SLd1	Adjusts motor 1 speed during slowing phases. This value is expressed in percentage.	30-70 (50%)	
SLd2	Adjusts motor 2 speed during slowing phases. This value is expressed in percentage.	30-70 (50%)	
SPd1	Adjusts motor 1 speed during normal speed phase. Value expressed in percentage.	30-99 (99%)	
SPd2	Adjusts motor 2 speed during normal speed phase. Value expressed in percentage.	30-99 (99%)	
PSo1	The anti-crash device* (amperometric sensor) operation is adjusted in the opening phase, at reduced speed - Motor 1.	1-99-(20%)**	
PSc1	The anti-crash device* (amperometric sensor) operation is adjusted in the closing phase, at reduced speed - Motor 1.	1-99-(20%)**	
PSo2	The anti-crash device* (amperometric sensor) operation is adjusted in the opening phase, at reduced speed - Motor 2.	1-99-(20%)**	
PSc2	The anti-crash device* (amperometric sensor) operation is adjusted in the closing phase, at reduced speed - Motor 2.	1-99-(20%)**	
SEAU	The intervention threshold of the anti-crashing device (Encoder) during the phase at normal speed is adjusted.* 0:Off-1:minimum sensitivity - 99: maximum sensitivity	0-99-(0%)	

SEAr	The intervention threshold of the anti-crashing device (Encoder) during braking is adjusted *. 0:Off-1:minimum sensitivity - 99: maximum sensitivity	0-99-(0%)	
t inc	This parameter is enabled only for motors equipped with Encoder. The encoder inhibition is regulated near the opening and closing mechanical stoppers. 1: minimum distance – 250: maximum distance	1-250-(250)	

*** WARNING:**

**AN INCORRECT SETTING OF THESE PARAMETERS MAY RESULT IN AN HAZARD.
COMPLY WITH REGULATIONS IN FORCE!**

With motors without limit switch and/or encoder it adjusts the sensitivity of the sensor which causes arrest during slowing phase.

** 1: minimum force/torque - 99: maximum force/torque.

The control unit is equipped with two ant-crash devices, the amperometric sensor (regulated by parameters PMO1/2-PMC1/2-PSO1/2-PSC1/2) and the encoder (regulated by parameters SEAV and SEAR).

The sensitivity of the amperometric sensor is regulated by default through the Autose procedure, while the encoder (with the default set) is activated only when the gate stops completely when it hits an obstacle.

The use of one system at a time is recommended, giving preference to the amperometric sensor, which has a lower response time.

LOGIC (LcL)

MENU	FUNCTION	ON-OFF-(Default)	MEMO
t cA	Enables or disables automatic closing On: automatic closing enabled Off: automatic closing disabled	(ON)	
ibL	Enables or disables condominium function. On: condominium function enabled. The step-by-step impulse or transmitter impulse has no effect during the opening phase. Off: condominium function disabled.	(OFF)	
ibcA	The multi-flat function is enabled or disabled during the TCA counting. On: the bloc of flat function is enabled. The Step-by-Step signal or the transmitter signal has no effect during the TCA counting. Off: the bloc of flat function is disabled.	(OFF)	
S cL	Enables or disables rapid closing On: rapid closure is enabled. With open gate, or in the opening phase, the activation of the photocell causes the automatic closure 3sec after the total opening of the gate. It is activated only with TCA:ON Off: rapid closing disabled.	(OFF)	
PP	Selects the operating mode of the "Step by step button" and of the transmitter. On: Operation: OPEN > CLOSE > OPEN > Off: Operation: OPEN > STOP > CLOSE > STOP >	(OFF)	
PrE	Enables or disables pre-blinking. On: Pre-blinking enabled. Blinking is activated 3s before the motor starts. Off: Pre-blinking disabled.	(OFF)	
hAn	Enables or disables the inversion stroke function On: Function enabled. Before each opening manoeuvre the control unit orders a manoeuvre of 2s in the opposite direction to facilitate the release of the electric lock. Off: Function disabled.	(OFF)	
bLcO	Enables or disables the block function in opening. On: Block function enabled. To use only with motors equipped with Limit switch. After the intervention of the opening Limit switch the control unit delays arrest by about 0.5s, so to allow a better strike of the shutter on the stop locks. Off: Block function disabled	(OFF)	
bLcC	Enables or disables the block function in closing. On: Block function enabled. To use only with motors equipped with Limit switch. After the intervention of the opening Limit switch the control unit delays arrest by about 0.5s, so to allow a better strike of the shutter on the stop locks. Off: Block function disabled.	(OFF)	
SoFt	Enables or disables start at decreased speed. On: Executes start ups at decreased speed for 2 seconds to then shift to normal speed. Off: Start at decreased speed not active.	(OFF)	
Lt cA	Selects the operating mode of the blinking light during the time TCA On: Blinking light on during TCA Off: Blinking light off during TCA	(OFF)	

htr	Enabled or disables HOLD-TO-RUN function On: HOLD-TO-RUN function. The pressure of the OPENS/CLOSES button must be maintained throughout the entire manoeuvre. The opening of the STOP input stops the motor. All the safety inputs are deactivated, except for the Limit switch inputs /SW01/SW02/SWC1/SWC2). Off: Automatic/semiautomatic function	(OFF)	
inot	The operating mode with 1 or 2 motors is selected: On: The motor operation is synchronised. This function must be used in the following cases: - for each single motor, connect it to M1: Terminals 1/2. - for two synchronised motors (e.g. balancing doors), connect one motor to M1: terminals 1/2 and the other to M2: terminals 3/4. Adjust the parameters related to motor 1, the M2 limit switch inputs are deactivated. TDMO and TDMC must be 0. Off: For two non-synchronised motors, e.g. overlapping gate leaves, adjust TDMO and TDMC on the desired values.	(OFF)	
cuAr	Enables or disables the programmable code transmitters. IMPORTANT: The transmitters with programmable code can only be used in conjunction with the Rolling Code HCS transmitters. On: Radio receiver enabled only for transmitters Rolling Code (ARC or HCS, the first transmitter sets the operating mode). Off: Receiver enabled for transmitters Rolling Code HCS and programmable (self-learning and dip/switch).	(ON)	
nLoc	Selects the type of electric lock used. On: Magnetic electric lock, normally fed at 12Vdc. Power is cut off to the electric lock output before each opening and closing operation. Off: Electric lock with latch, normally not fed. Before each opening manoeuvre power is fed at 12Vdc for the time set by the parameter TLOC.	(OFF)	
bb	Activates or deactivates the push in closing function. Only with logic SLD:ON On: The last second of the manoeuvre in closing phase is carried out at normal speed (disabling slowing) to favour a better hook of the electric lock. Off: Function disabled.	(OFF)	
2ch	Enables or disables the second radio channel on terminals 29/30. On: Exit 29/30 configured with function as second radio channel. Off: Exit 29/30 takes on function of service light (see parameter TLS).	(OFF)	
tSt1	Enables or disables checking of photocells on PHOT input, active both in closing and in opening. On: Check enabled. If the check has a negative result, no manoeuvre is commanded. See Fig.4 - "PHOTO TEST". Off: Checking of photocells disabled at each manoeuvre.	(OFF)	
tSt2	Enables or disables checking of photocells on PHOT inputs, active only in closing. On: Check enabled. If the check has a negative result, no manoeuvre is commanded. See Fig.4 - "PHOTO TEST". Off: Checking of photocells disabled at each manoeuvre.	(OFF)	
tStn	Enables or disables motors check. On: Check enabled. If the check has a negative result, no manoeuvre is commanded. Off: Check disabled.	(OFF)	
rEn	(Enables or disables remote radiotransmitters learning, as indicated in the paragraph "Remote transmitters learning". On: Remote learning enabled. Off: Remote learning not enabled.	(OFF)	

RADIO (rRd)

MENU	FUNZIONE
<i>pp</i>	By selecting this function, the receiver goes in waiting (<i>PU5h</i>) for a transmitter code to assign to the step-step function. Press the key of the transmitter to assign to this function. If the code is valid, it is memorised and the message <i>oH</i> is displayed If the code is not valid, the message <i>Err</i> is displayed
<i>2ch</i>	By selecting this function, the receiver goes into waiting (<i>PU5h</i>) for a transmitter code to assign to the second radio channel. Press the key of the transmitter to assign to this function. If the code is valid, it is memorised ad the <i>oH</i> message is displayed If the code is not valid, the message <i>Err</i> is displayed.
<i>PEd</i>	By selecting this function, the receiver goes into waiting (<i>PU5h</i>) for a transmitter code to assign to the pedestrian opening function (see parameter TPED). Press the key of the transmitter to assign to this function. If the code is valid, it is memorised ad the <i>oH</i> message is displayed If the code is not valid, the message <i>Err</i> is displayed.
<i>clr</i>	By selecting this function, the receiver goes into waiting (<i>PU5h</i>) for a transmitter code to erase from the memory. If the code is valid, it is erased and the message <i>oH</i> is displayed If the code is not valid or not present in memory, the message <i>Err</i> is displayed
<i>rtr</i>	Completely erases memory of the receiver. Confirmation of the operation is requested. By selecting this function the receiver goes into waiting (<i>PU5h</i>) for a new PGM pressure to confirm the operation. At end of erasing the <i>oH</i> message is displayed

CYCLES NUMBER (nRRn)

Displays the number of complete cycles (open+close) carried out by the automation.
When the <PG> button is pressed for the first time, it displays the first 4 figures, the second time it shows the last 4. Example <PG> *00 12 >>>* <PG> *3456*: made 123.456 cycles.

MAINTENANCE CYCLES (nRc i)

This function enables to activate the maintenance request notice after a number of manoeuvres determined by the installer.
To activate and select the number of manoeuvres, proceed as follows:
Press button <PG>, the display will show OFF, which indicated that the function is disabled (default value).
With the buttons <+> and <-> select one of the numeric values proposed (from OFF to 100). The values are intended as hundreds of cycles of manoeuvres (for example: the value 50 indicates 5000 manoeuvres).
Press the OK button to activate the function. The display will show the message *Pr o ũ*.
The maintenance request is indicated to the user by keeping the indicator lamp lit up for other 10 sec after the conclusion of the opening or closing operation.

RESET (rE5)

RESET of the control unit. ATTENTION!: Returns the control unit to the default values.
Pressing the <PG> button for the first time causes blinking of the letters *rE5*, pressing the <PG> button again resets the control unit.
Note: The transmitters are not erased from the receiver nor is the access password.
All the logics and all the parameters are brought back to default values, it is therefore necessary to repeat the autoset procedure.

AUTOSSET (RUt o)

This function is used to set the optimal operating values of the automatic system and, at the end of the procedure, the LAG, OPERATING TIME and BRAKING parameter are adjusted.
To carry out autoset, proceed as follows:
a) Ascertain that no obstacles of any nature are present in the manoeuvre area, if necessary, block off the area in order to prevent access from people, animals, vehicles, etc.
During autoset phase, the anti-crushing function is not active.
b) Select the AUTO function and press OK.
c) Select with the <+> or <-> button the submenu, NOLS, LSW or ENC based on the presence of Limit switch and/or encoder:
NOLS: if the motor is without Limit switch and encoder
LSW: if the motor is equipped with Limit switch and without encoder
ENC: if the motor is equipped with encoder and without Limit switch
d) once selected press OK to begin the autoset phase.
The control unit carries out a series of manoeuvres for learning of the run of the leaves and for parameter configuration.
Initially both the leaves are brought to opening position, then after some opening and closing manoeuvres at different speeds, of one or both the shutters, the control unit displays the message *oH*. In case the operation has no positive result, the message *Err* is displayed.
Repeat the operation after re-checking the wiring and the eventual presence of obstacles.
In case parameters TM1/TM2 or the speed are changed, repeat the autoset procedure.
During the manoeuvres the display will show some abbreviations: OPM1/OPM2 during opening of the motor 1 or 2 and CLM1/CLM2 during closing of motor 1 or 2.

PROTECTION CODE (codE)

It allows to type in an access protection code to the programming of the control unit.

A four-character alphanumeric code can be typed in by using the numbers from 0 to 9 and the letters A-B-C-D-E-F.

The default value is 0000 (four zeros) and shows the absence of a protection code.

While typing in the code, this operation can be cancelled at any moment by pressing keys + and – simultaneously. Once the password is typed in, it is possible to act on the control unit by entering and exiting the programming mode for around 10 minutes in order to allow adjustments and tests on functions.

By replacing the 0000 code with any other code, the protection of the control unit is enabled, thus preventing the access to any other menu. If a protection code is to be typed in, proceed as follows:

- select the Code menu and press OK.
- the code 0000 is shown, also in the case a protection code has been previously typed in.
- the value of the flashing character can be changed with keys + and -.
- press OK to confirm the flashing character, then confirm the following one.
- after typing in the 4 characters, a confirmation message “CONF” appears.
- after a few seconds, the code 0000 appears again
- the previously stored protection code must be reconfirmed in order to avoid any accidental typing in.

If the code corresponds to the previous one, a confirmation message “oH” appears.

The control unit automatically exits the programming phase. To gain access to the Menus again, the stored protection code must be typed in.

IMPORTANT: TAKE NOTE of the protection code and KEEP IT IN A SAFE PLACE for future maintenance operations.

To remove a code from a protected control unit it is necessary to enter into programming with the password and bring the code back to the 0000 default value.

IF YOU LOOSE THE CODE, PLEASE CONTACT THE AUTHORISED SERVICE CENTER FOR THE TOTAL RESET OF THE CONTROL UNIT.

HOW TO ADJUST THE GATE SPEED

The duration of the movement at regular speed and therefore the duration of braking can be preset through parameters TM1 and TM2.

If the motor is equipped with Encoder:

- Carry out an Autotest for the self-learning of values.
- Preset parameters TM1/TM2, taking account that they indicate the percentage value of stroke at regular speed.
- Preset the other parameters for speed and torque in compliance with the type of installation and regulations in force.

If the motor is not equipped with Encoder:

- Carry out an Autotest for the self-learning of values, and check duration of the opening and closing operation.
- Preset the value read on TM1/TM2 parameter, deducting the desired braking time (for example: a 25sec total opening and a 5 sec braking is required: preset TM1/TM2 on 20sec).
- Preset the other parameters for speed and torque in compliance with the type of installation and regulations in force.

TRANSMITTERS REMOTE LEARNING

If an already memorised transmitter is available in the receiver it is possible to carry out remote radio learning (without needing to access the control unit).

IMPORTANT: The procedure must be carried out with leaves in opening during TCA pause or with an open gate if the TCA logic is OFF. The REM logic must be ON.

Proceed as follows:

- 1 Press the hidden key of the transmitter which is already memorised.
- 2 Press, within 5s, the key of the corresponding transmitter which is already memorised to associate to the new transmitter. The flashing light will turn on.
- 3 Press within 10s the hidden key of the new transmitter.
- 4 Press, within 5s, the key of the new transmitter to associate to the channel chosen at point 2. The flashing light will turn off.
- 5 The receiver memorised the new transmitter and immediately exits from programming.

FUSES

F1 BRAINY24-SW/+:	T2A - Fuse for the protection of the accessories power supply
F1 SA.24V:	T4A - Fuse for general protection
F1 SAR.24V:	T2A - Fuse for general protection

BACK UP BATTERIES

The control unit BRAINY 24 includes the power pack SA.24V predisposed for the connection in series of two batteries by 12Vdc 2,1Ah DA.BT2 (optional) which guarantee the regular functioning of the automation in case of temporary power failure.

When the barrier is working with mains voltage the power pack SA.24V charges the batteries (Fig. 1/2).

The maximum charging current is 1A, the average charging current is 300 mA (Observe the polarity).

DIAGNOSTICS

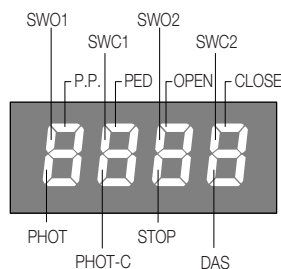

One segment of the display is linked to each input. In the event of failure it switches on according to the following scheme.

N.C. inputs are represented by the vertical segments. N.O. inputs are represented by the horizontal segments.

The control unit sees the message AMP1 or AMP2 in case of anti-crushing ammeter sensor intervention.

ERROR MESSAGES

Some messages that are displayed in case of function anomalies are listed as follows:

<i>AMP 1</i>	Obstacle error motor 1/anti-crushing	Check presence of obstacles on motor 1 leaf run
<i>AMP 2</i>	Obstacle error motor 2/anti-crushing	Check presence of obstacles on motor 2 leaf run
<i>ENC 1</i>	Error, encoder 1/detection of the obstacle	Check the correct connection of motor 1 encoder to the control unit, that no obstacles are present along the gate stroke and the encoder operates correctly.
<i>ENC 2</i>	Error, encoder 2/detection of the obstacle	Check the correct connection of motor 2 encoder to the control unit, that no obstacles are present along the gate stroke and the encoder operates correctly.
<i>ERR 1</i>	Motor 1 circuit checking error	Check motor 1 connections
<i>ERR 2</i>	Motor 2 circuit checking error	Check motor 2 connections
<i>ERR 3</i>	error/fault power circuit	Request technical assistance and eventually replace control unit.
<i>ERR 4</i>	PHOTA photocell checking error	Check connections, PHOT A photocell alignment or presence of obstacles.
<i>ERR 5</i>	PHOTC photocell checking error	Check connections, PHOTC photocell alignment or presence of obstacles.
<i>ERR 6</i>	Error edge active (during autoset)	In autoset phase, the safety edge has intervened.
<i>ERR 7</i>	Error active stop (during autoset)	In autoset phase, the STOP input has intervened.
<i>ERR 8</i>	Error active input (during autoset)	In autoset phase a PP/Open/Close input has intervened.
<i>Thrn</i>	Motor thermal protection intervention	Wait for motor cooling, in case reset does not take place, motor replacement may be necessary

TECHNICAL DATA

Control unit supply	24 Vdc
Power supply	100÷250 Vac 50/60 Hz
Output supply	1/2 motor 24Vdc
Maximum motor current	5+5 A
Output supply accessories	24Vdc 500mA max.
Protection level	IP55
Operating temp.	-20°C / +50°C
Radio receiver	built in 433,92 MHz configurable
Rolling code transmitters supported	64

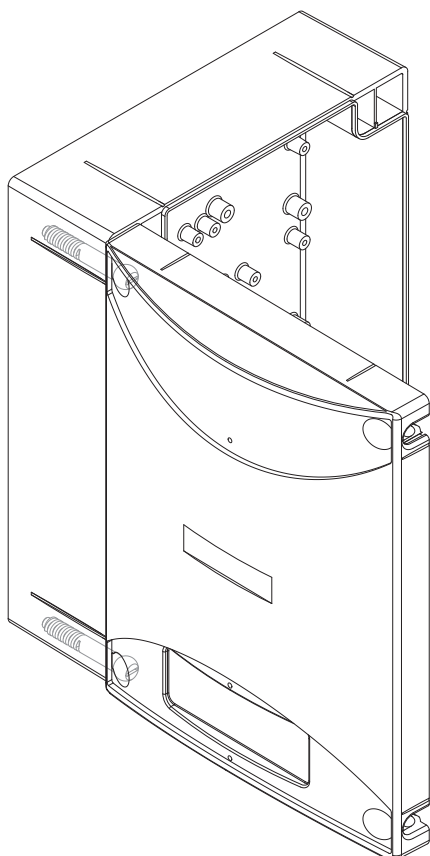
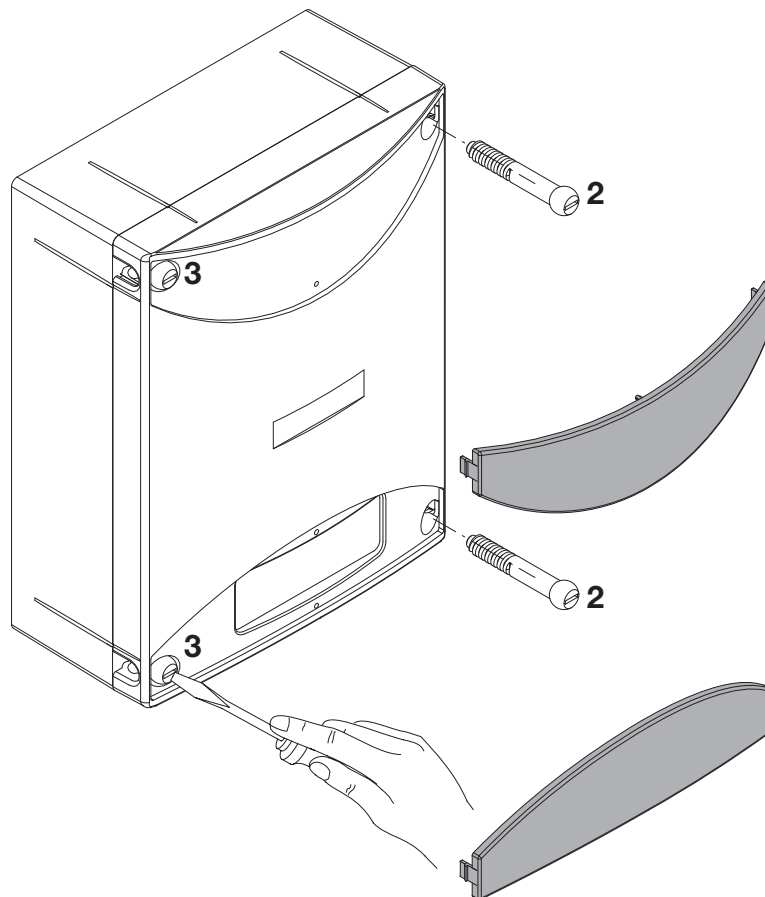
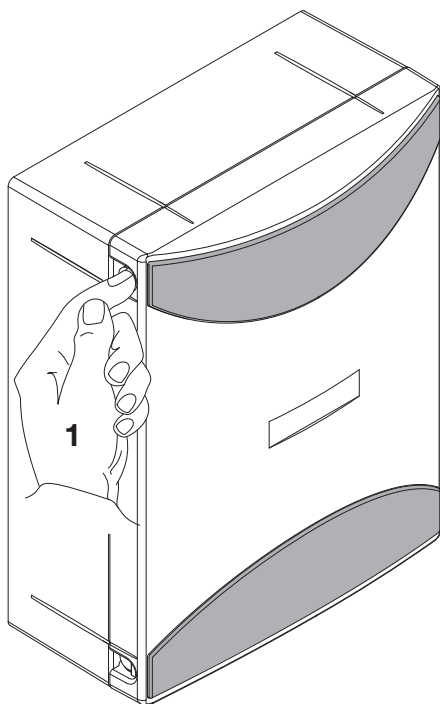

1. Premere le alette sui fianchi per sganciare le due maschere copriviti.
 2. Rimuovere le due viti sul lato di apertura desiderato.
 3. Allentare le viti con funzione di cerniera senza rimuoverle, in modo da consentire l'apertura del coperchio.

1. Press the tabs on the sides to release the two masks that cover the screws.
 2. Remove the two screws on the desired opening side.
 3. Slacken the two screws that act as a hinge without removing them, so as to allow opening the cover.

1. Auf die seitlichen Laschen drücken, so dass die beiden Schraubenblenden befreit werden.
 2. Die beiden Schrauben an der gewünschten Öffnungsseite ausbauen.
 3. Zuletzt die beiden als Scharnier dienenden Schrauben lockern, aber nicht ausbauen, damit der Deckel geöffnet werden kann.

1. Presser les deux ailettes latérales pour décrocher les deux cache-vis.
 2. Enlever les deux vis sur le côté d'ouverture désiré.
 3. Desserrer les deux vis faisant fonction de charnière sans les enlever, de manière à permettre l'ouverture du couvercle.

1. Presionar las aletas en los lados para desenganchar las dos tapas cubretornillos.
 2. Extraer los dos tornillos del lado de apertura deseado.
 3. Afojar los dos tornillos con función de bisagra sin extraerlos, a fin de poder abrir la tapa.

1. Nacisnąć boczne klapki w celu odhaczenia dwóch masek nakrywających śruby.
 2. Wyciągnąć dwie śruby po wybranej do otwierania stronie.
 3. Poluzować dwie śruby blokujące bez wyciągania ich, w sposób umożliwiający otwarcie nakrywkki.

BENINCA[®]
 TECHNOLOGY TO OPEN