

EVA.8

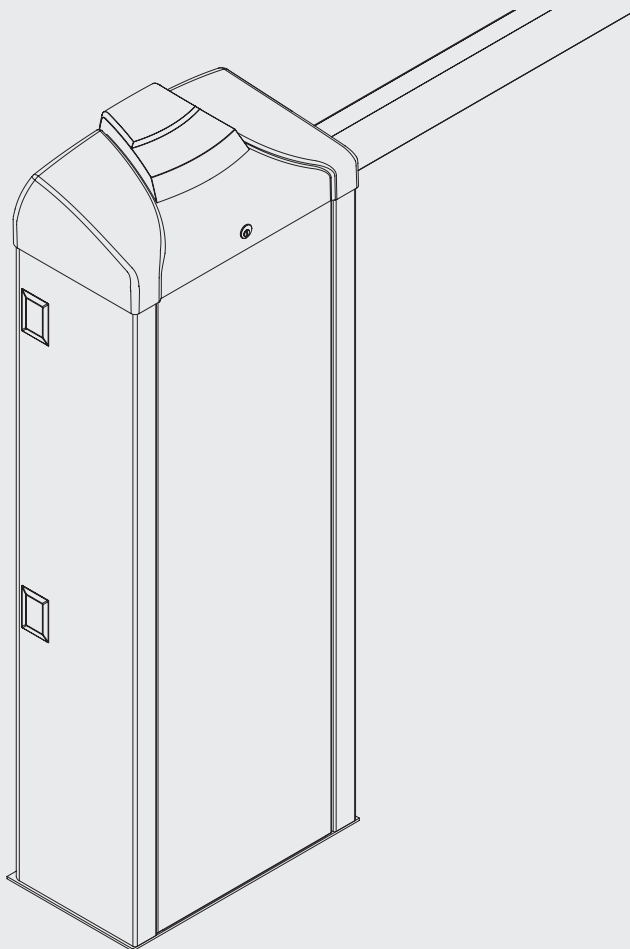

**Boom Gate
Tips N Tricks
at the back.**



BENINCA[®]
TECHNOLOGY TO OPEN



1

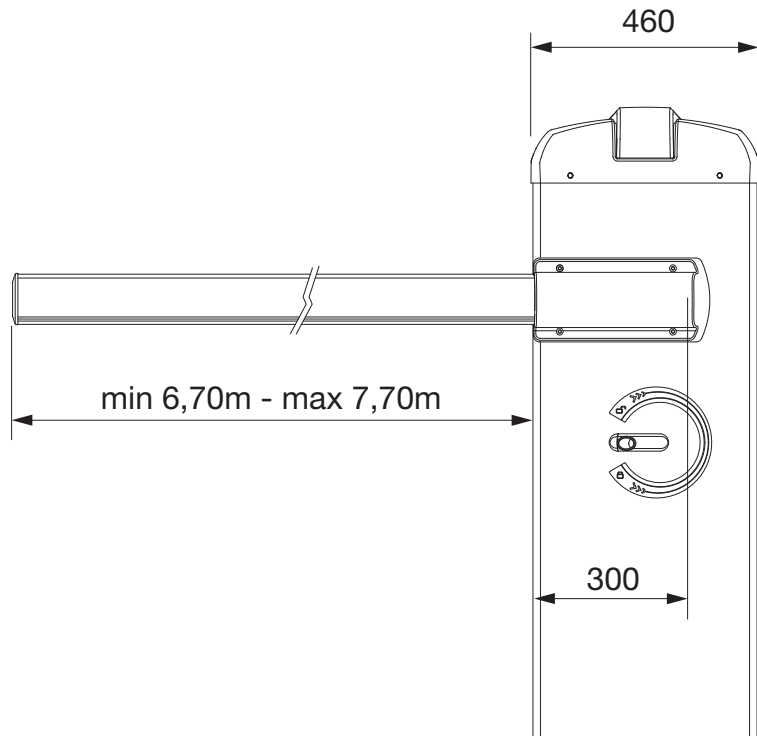
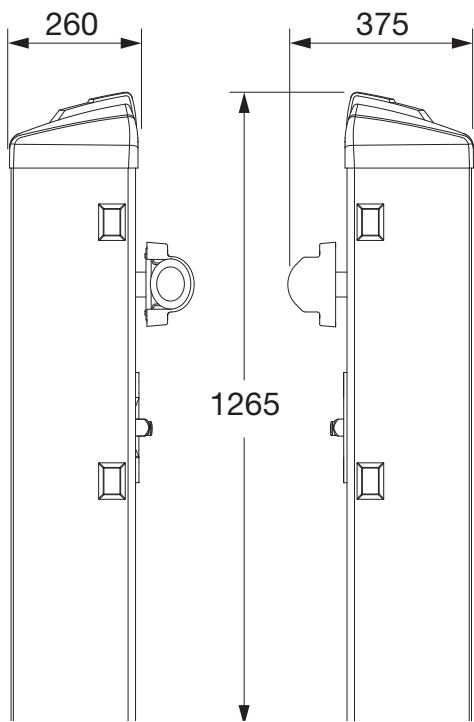

2

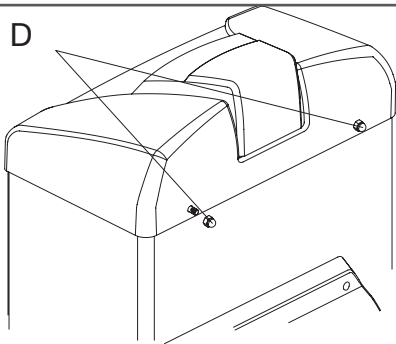

A

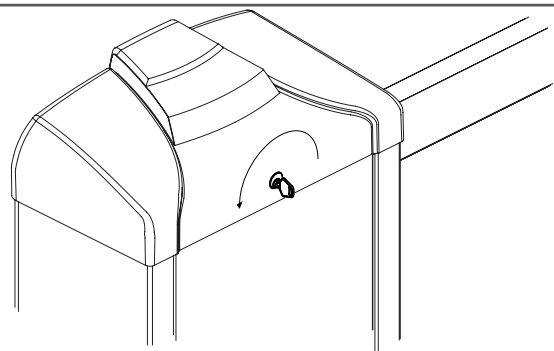

B

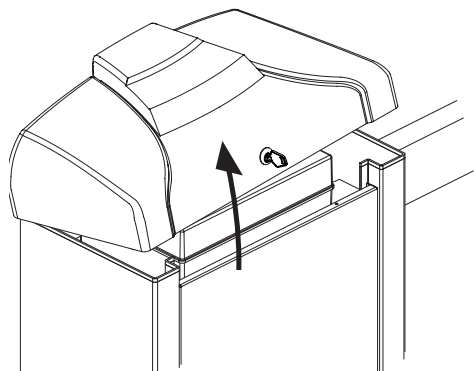

C

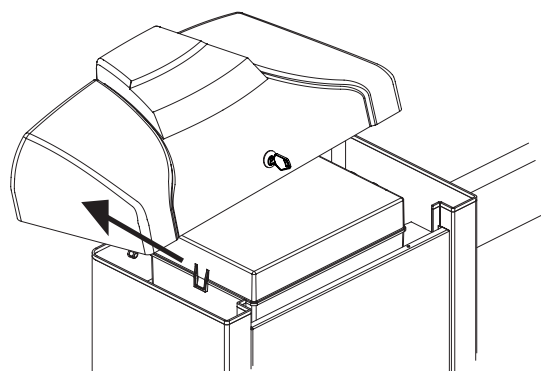

D

3

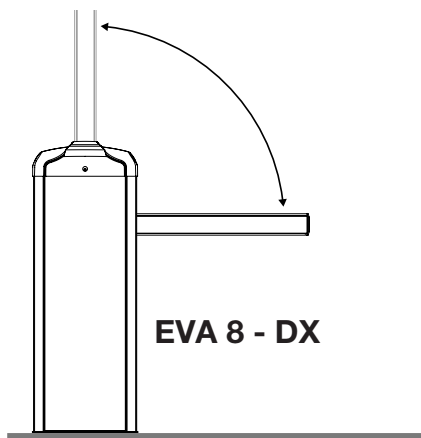

A

EVA 8 - DX

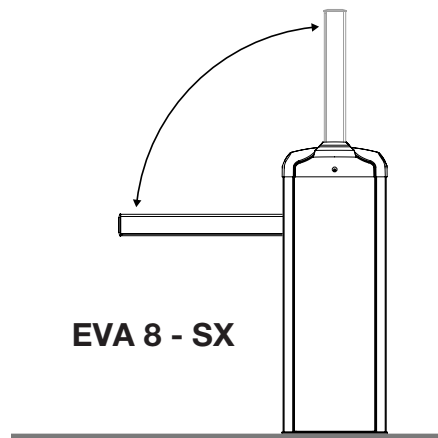

B

EVA 8 - SX

4

EVA8 - RIGHT
(STANDARD)

A

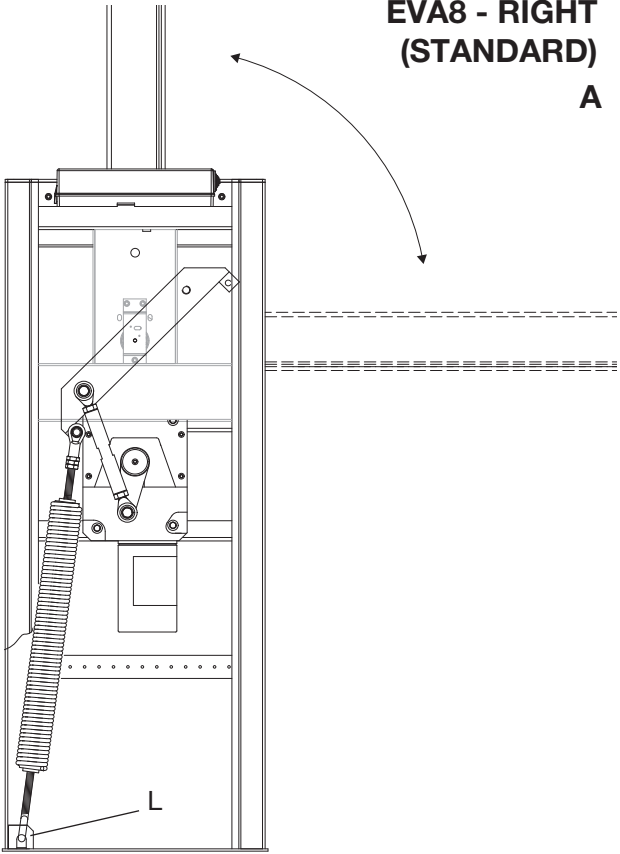

EVA8 - LEFT

B

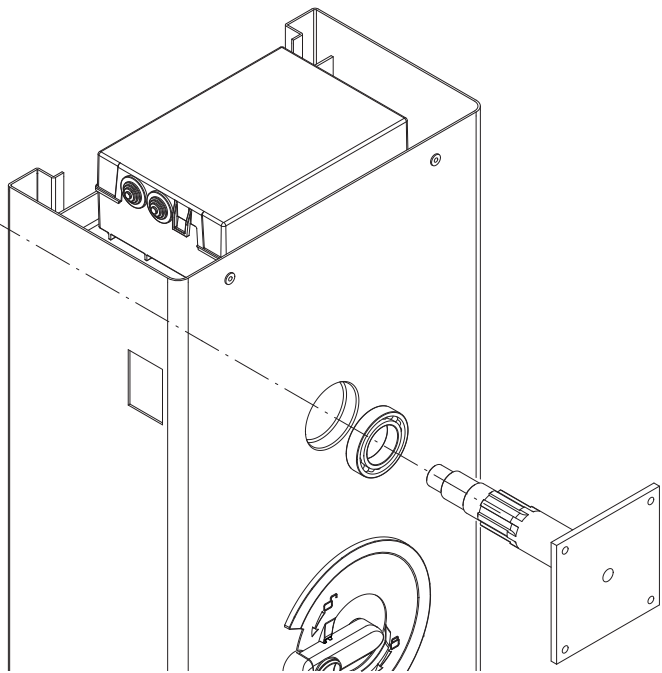
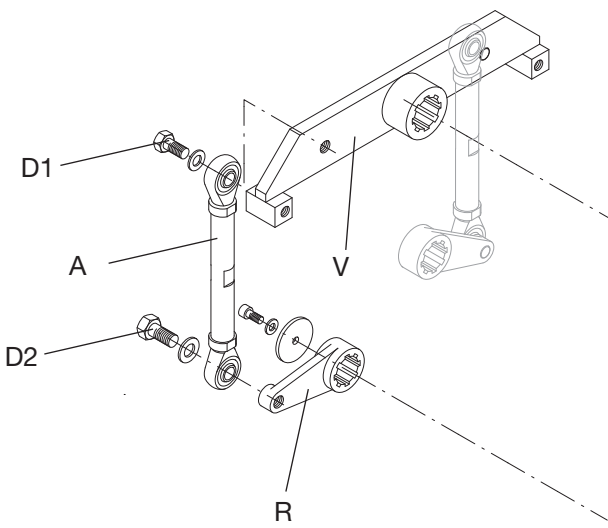
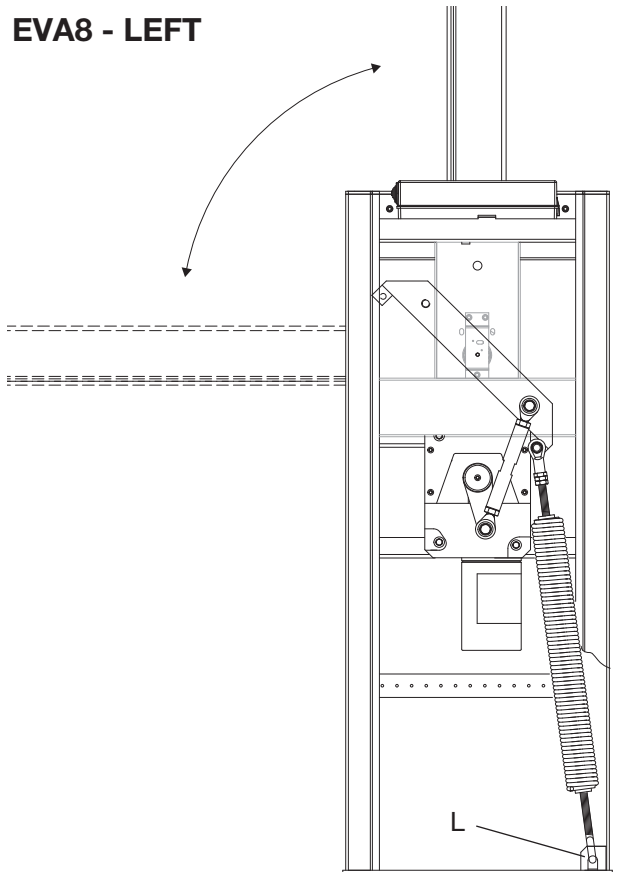

5

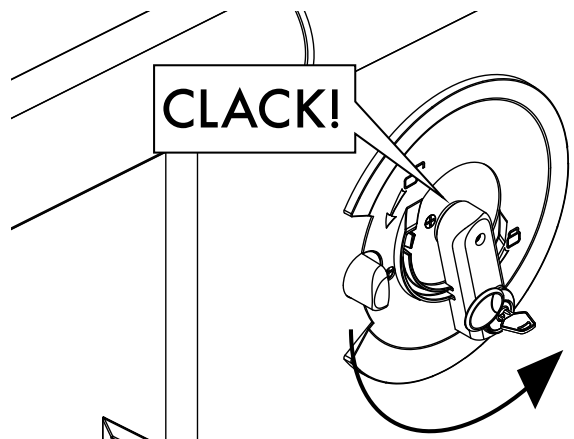
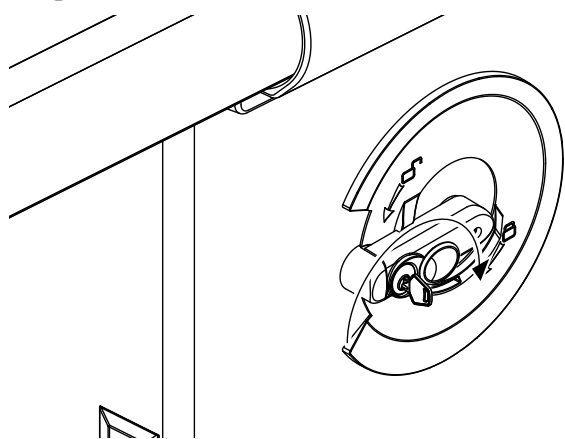

6

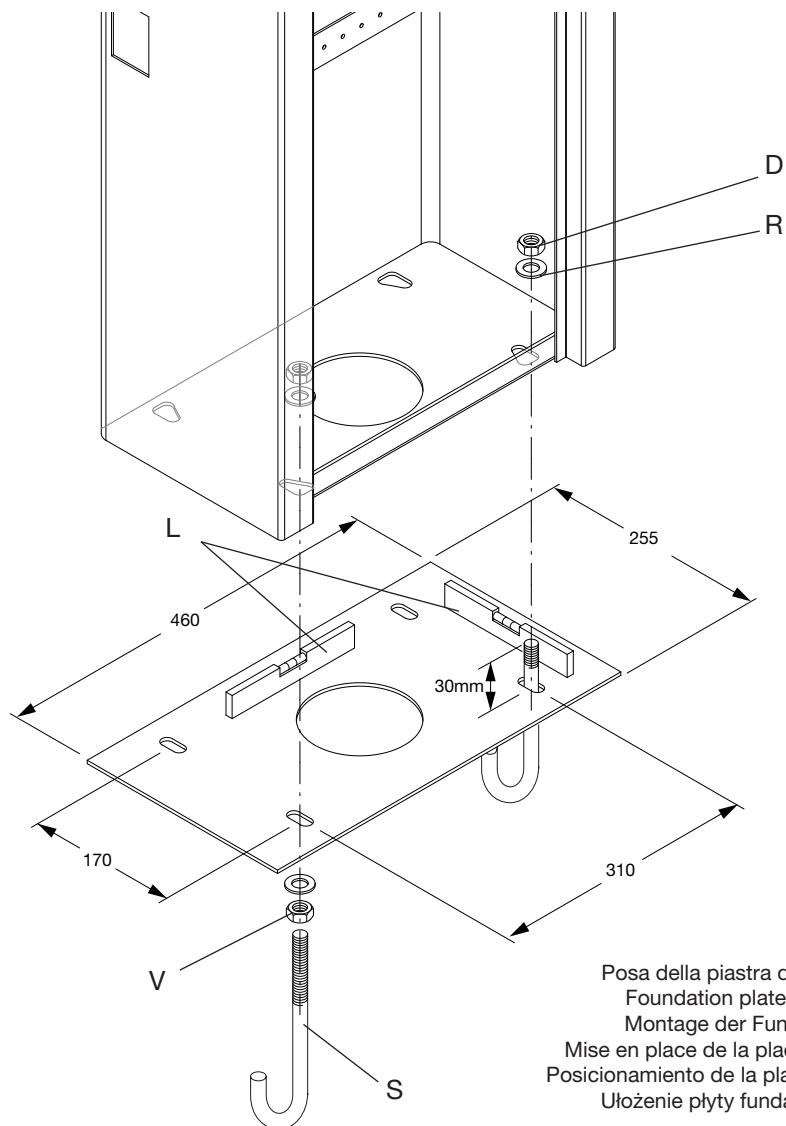

Posa della piastra di fondazione VE.P650 (opzionale)
 Foundation plate positioning VE.P650 (optional)
 Montage der Fundamentplatte VE.P650 (option)
 Mise en place de la plaque de fondation VE.P650 (optionnel)
 Posicionamiento de la placa de alimentación VE.P650 (opcional)
 Ułożenie płyty fundamentowej VE.P650 (opcjonalna)

7

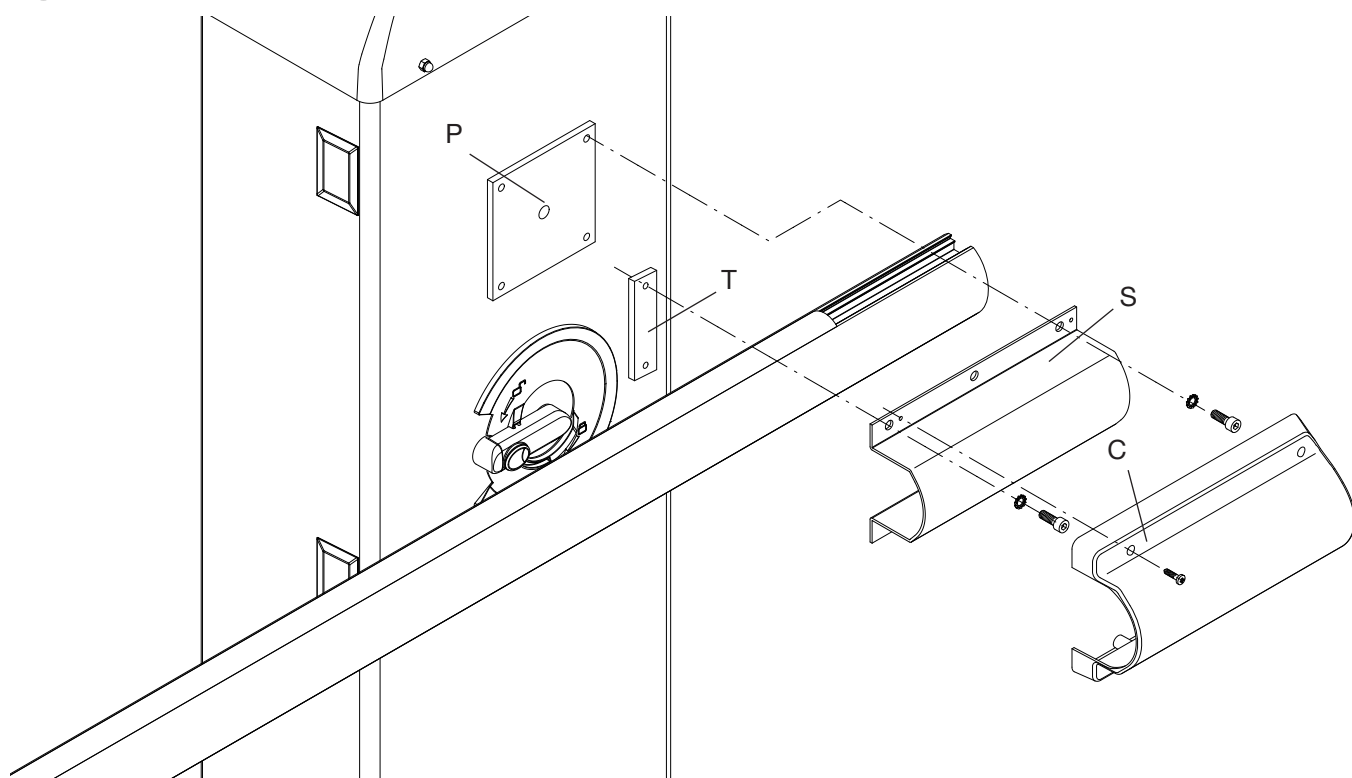

8

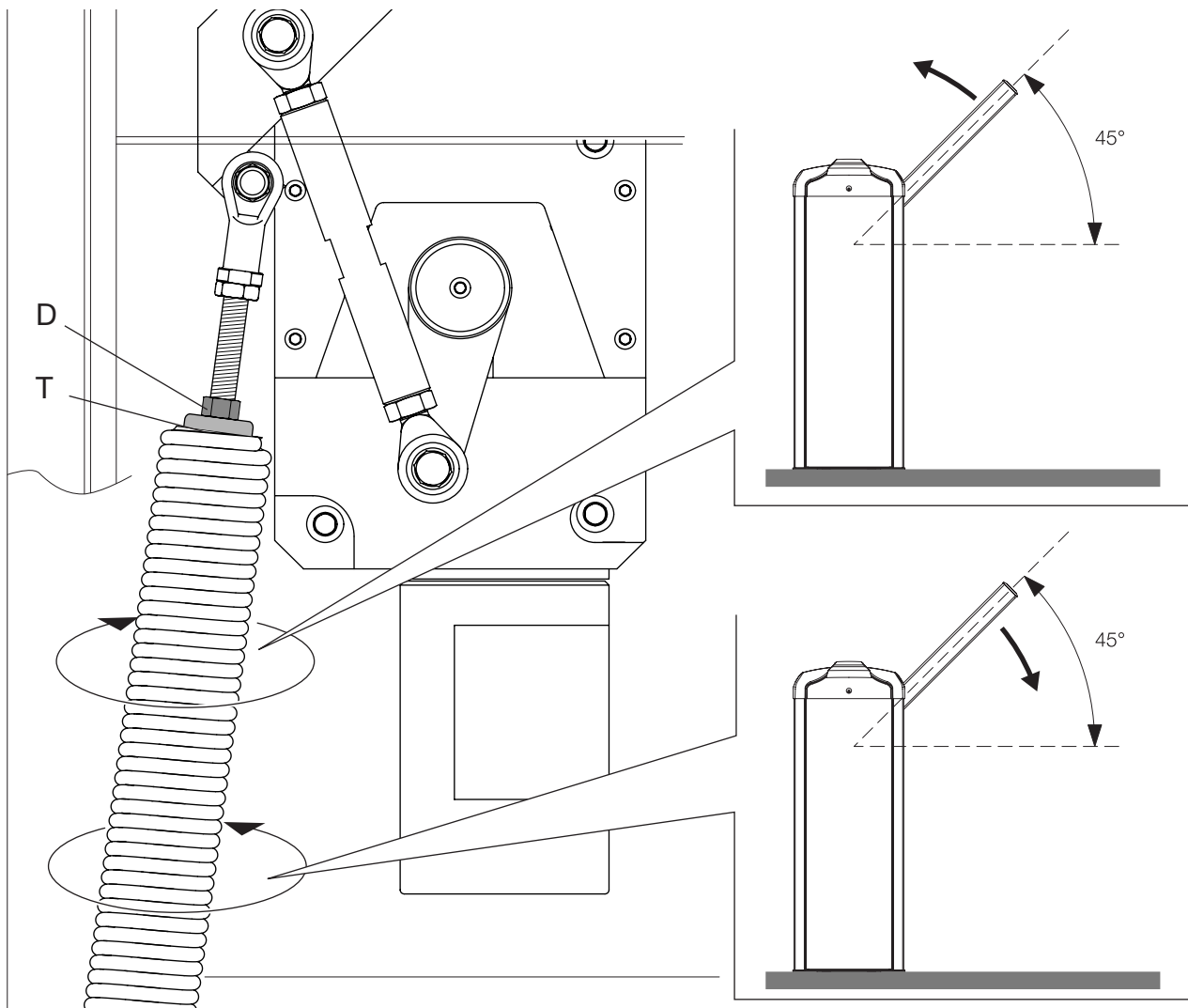

9

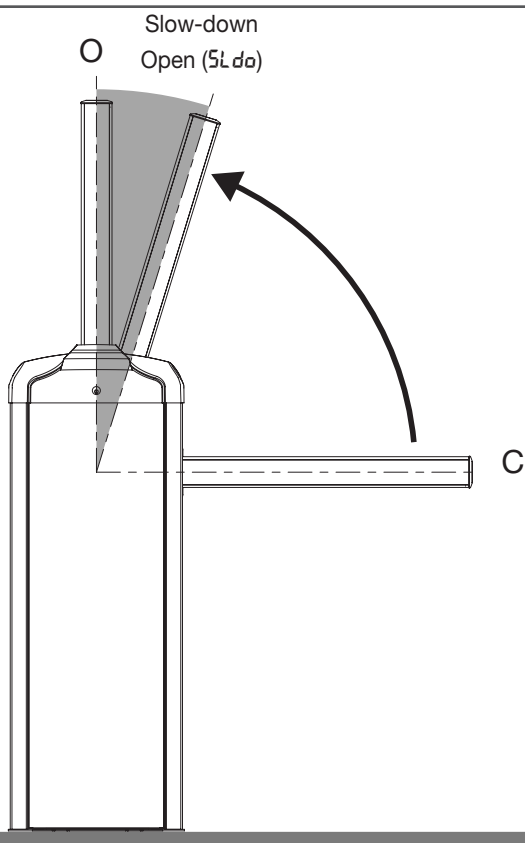

10

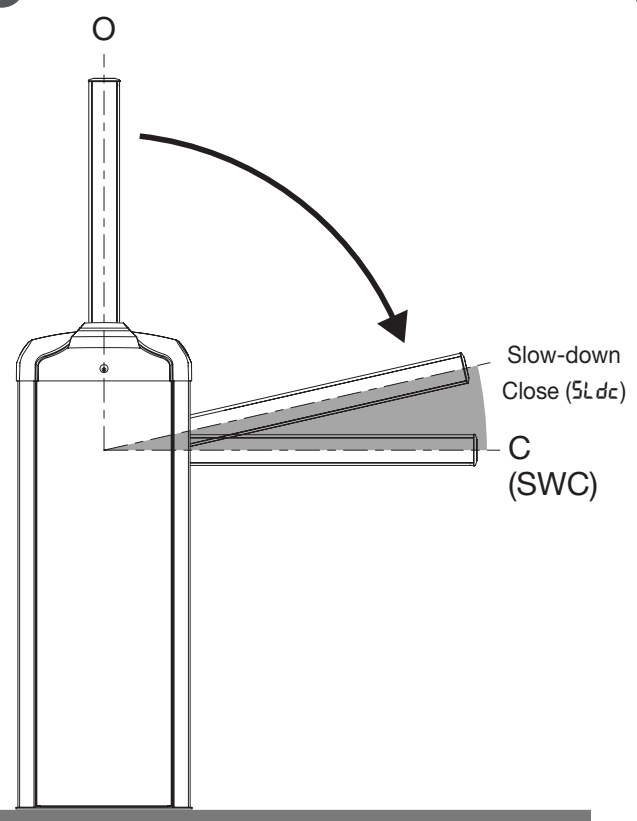

11

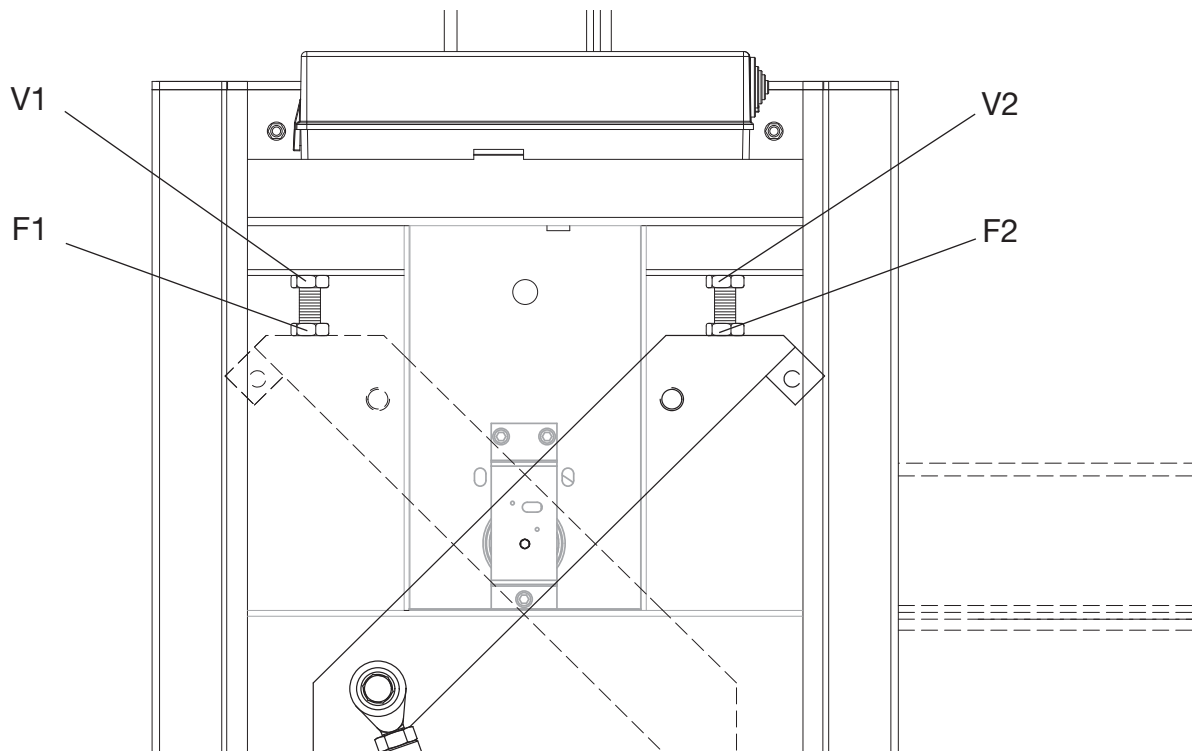

12

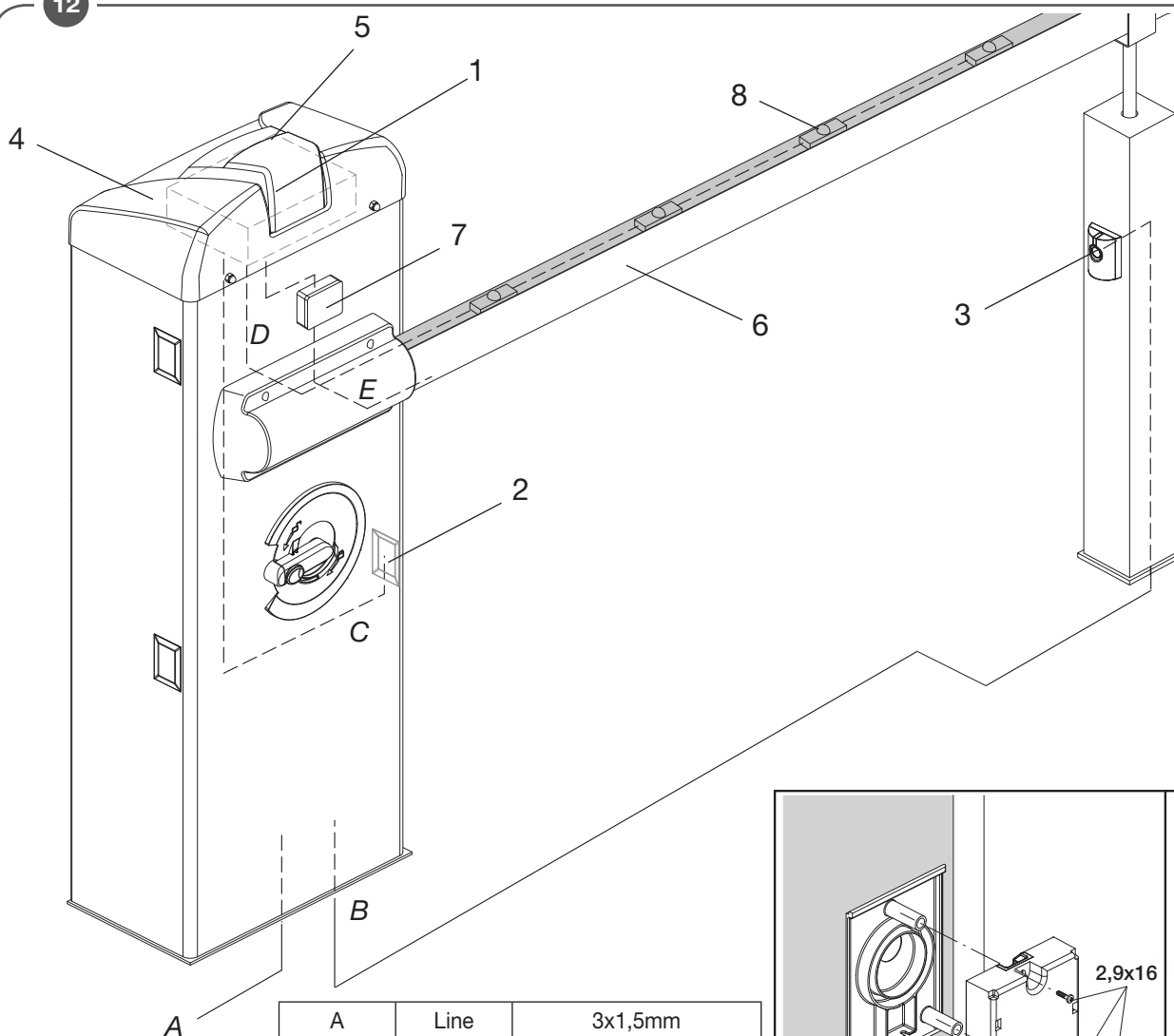

A	Line	3x1,5mm
B	Photo TX	2x0,5mm
C	Photo RX	4x0,5mm
D	EVA.Led	2x0,5mm
E	SC.EN	2x0,5mm

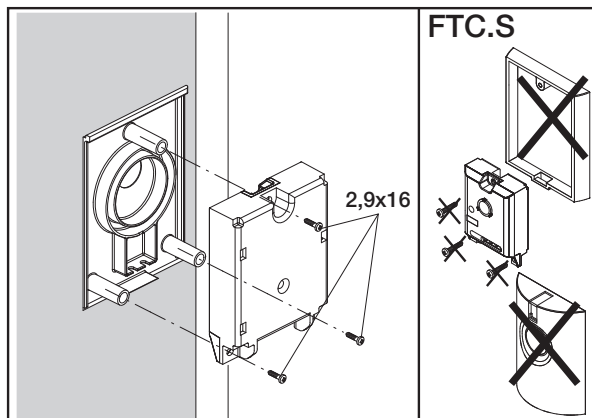

SOSTITUZIONE MOLLA
SPRING REPLACEMENT
FRÜHLING-ERSATZ
REEMPLACEMENT DES RESSORTS
REEMPLAZO DEL RESORTE
WYMIANA SPRĘŻYNY

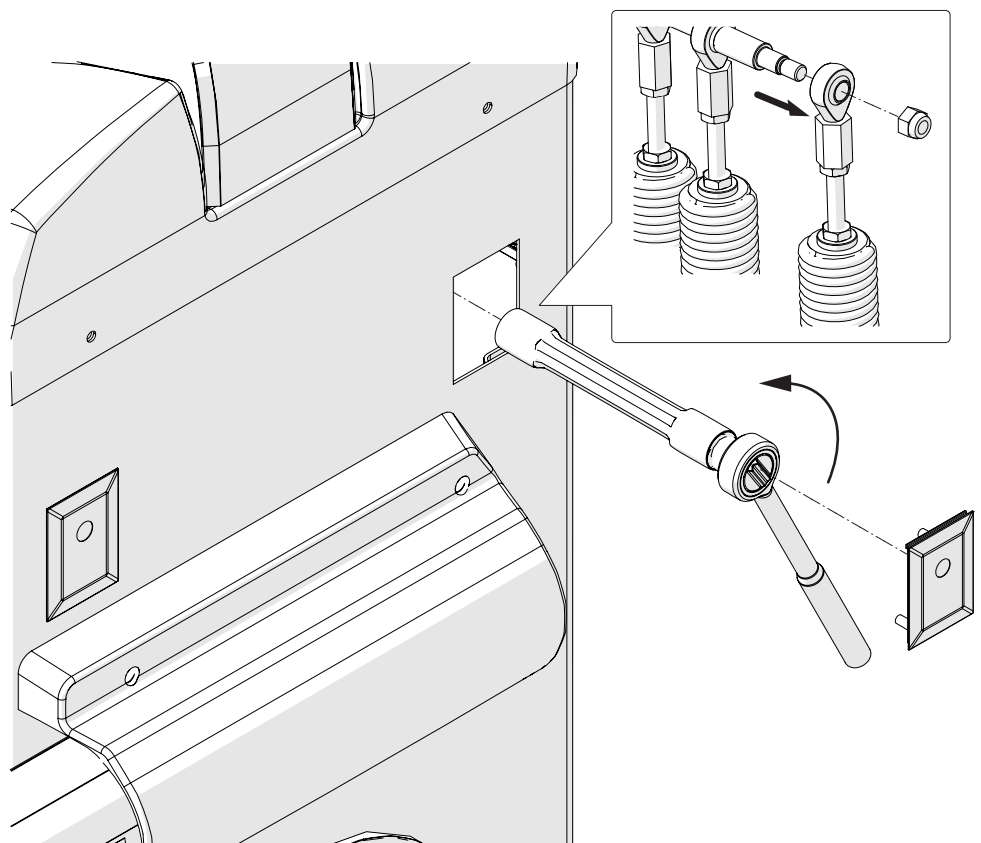

ASSEMBLAGGIO ASTA 8M
8M ROD ASSEMBLY
8M STAB-MONTAGE
TIGE ARTICULÉE 8M
MONTAJE DE LA BARRA 8M
8M PRZY MONTAŻU TŁOCZYSKA

A

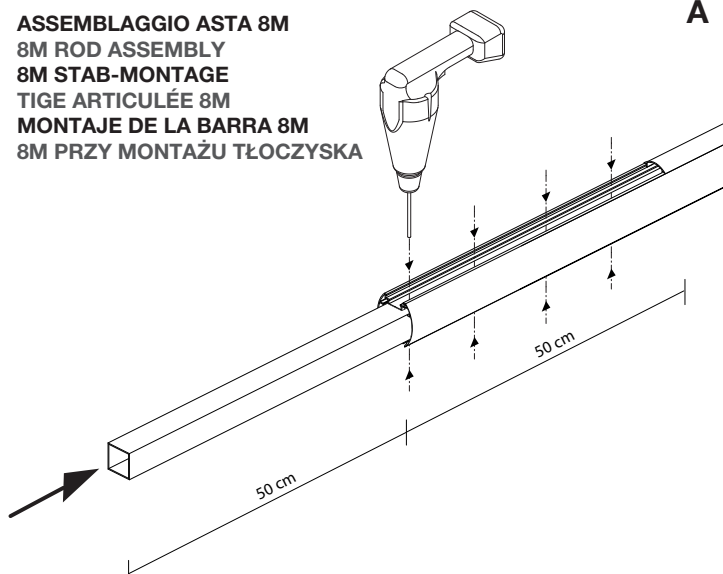

B

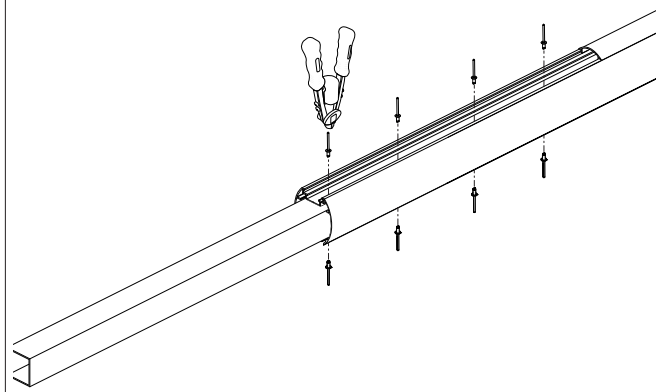

C

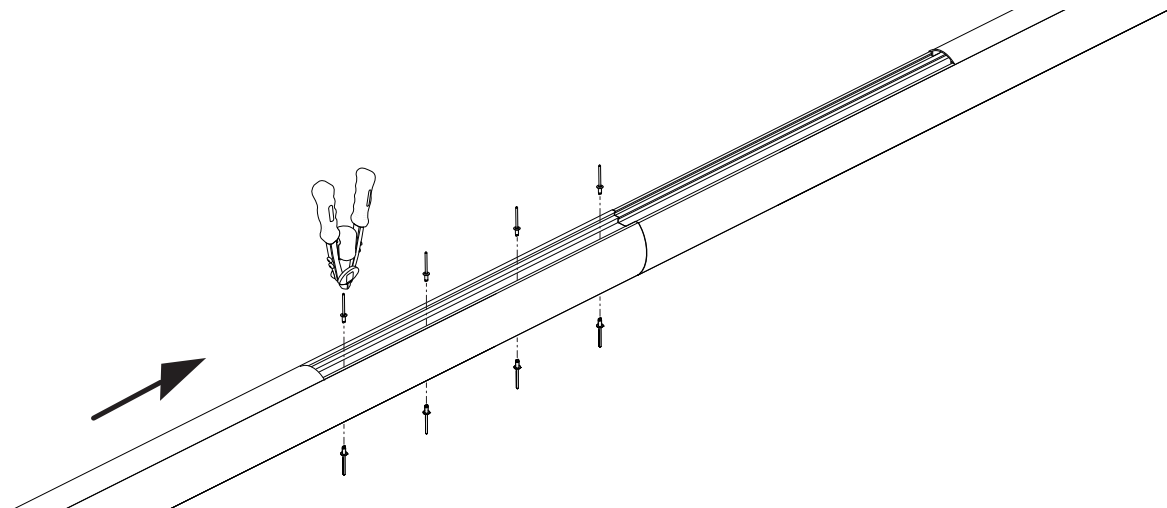

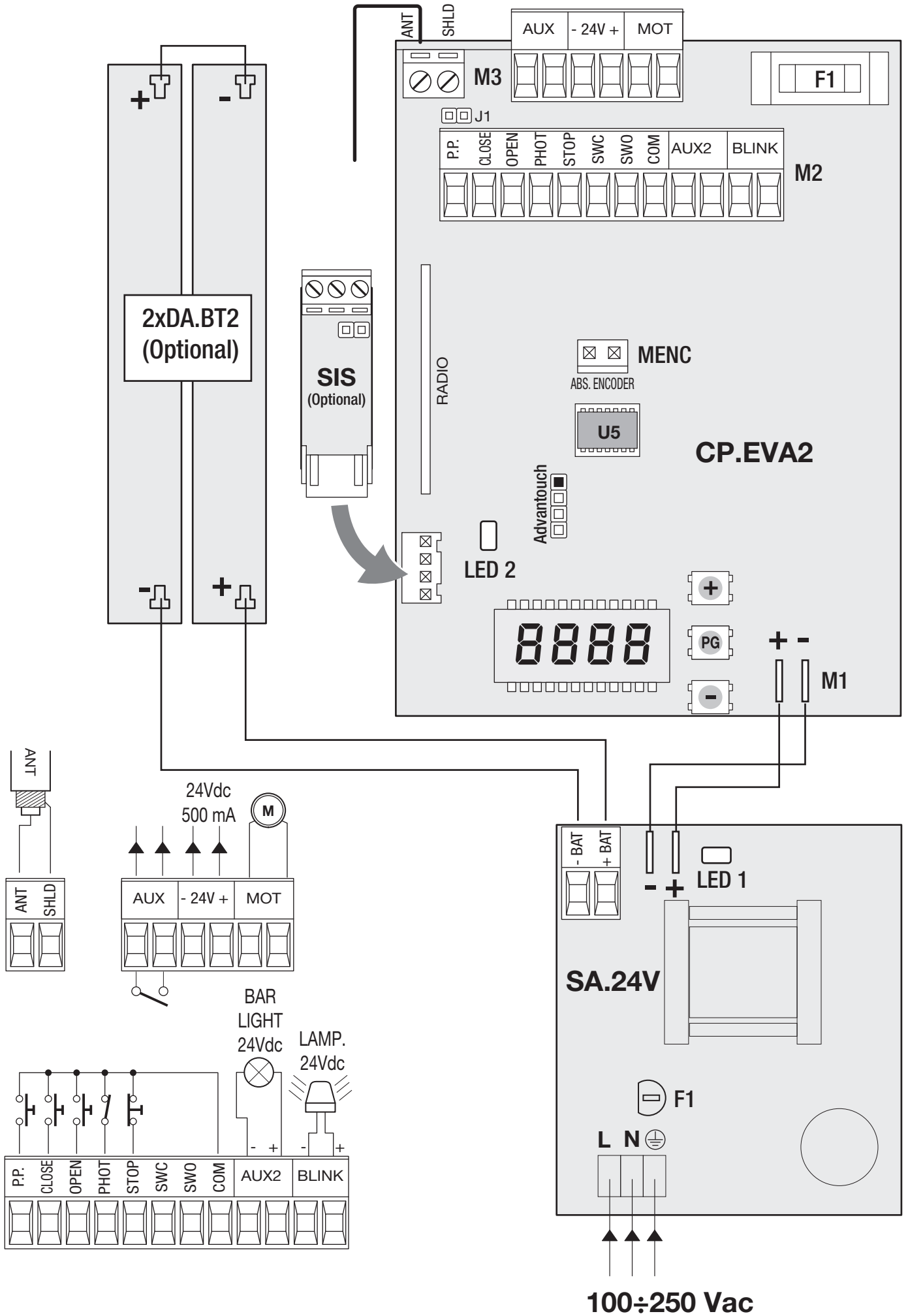

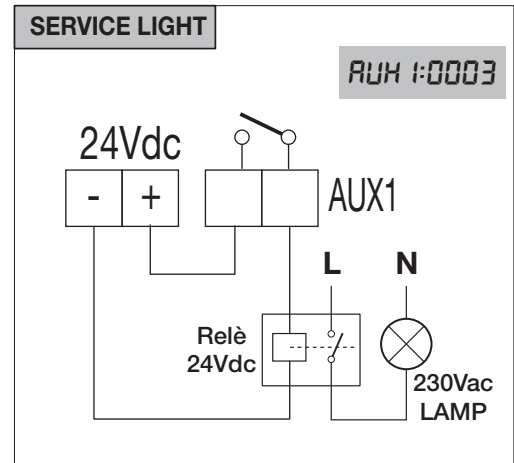
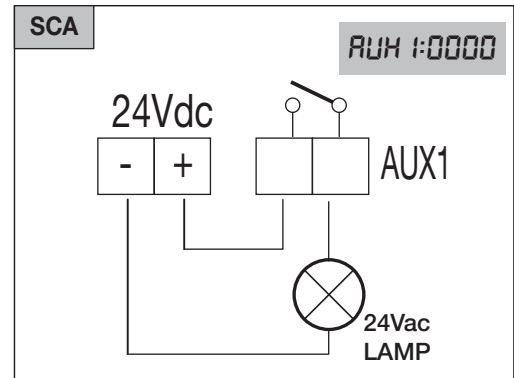
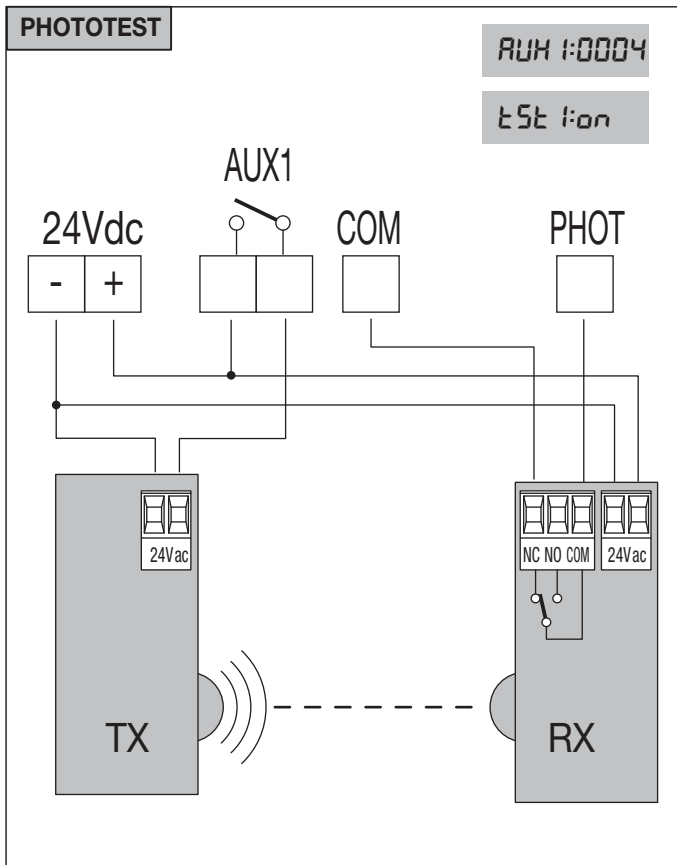

MASTER
Menu *bus*
Id=0

SLAVE
Menu *bus*
Id=1

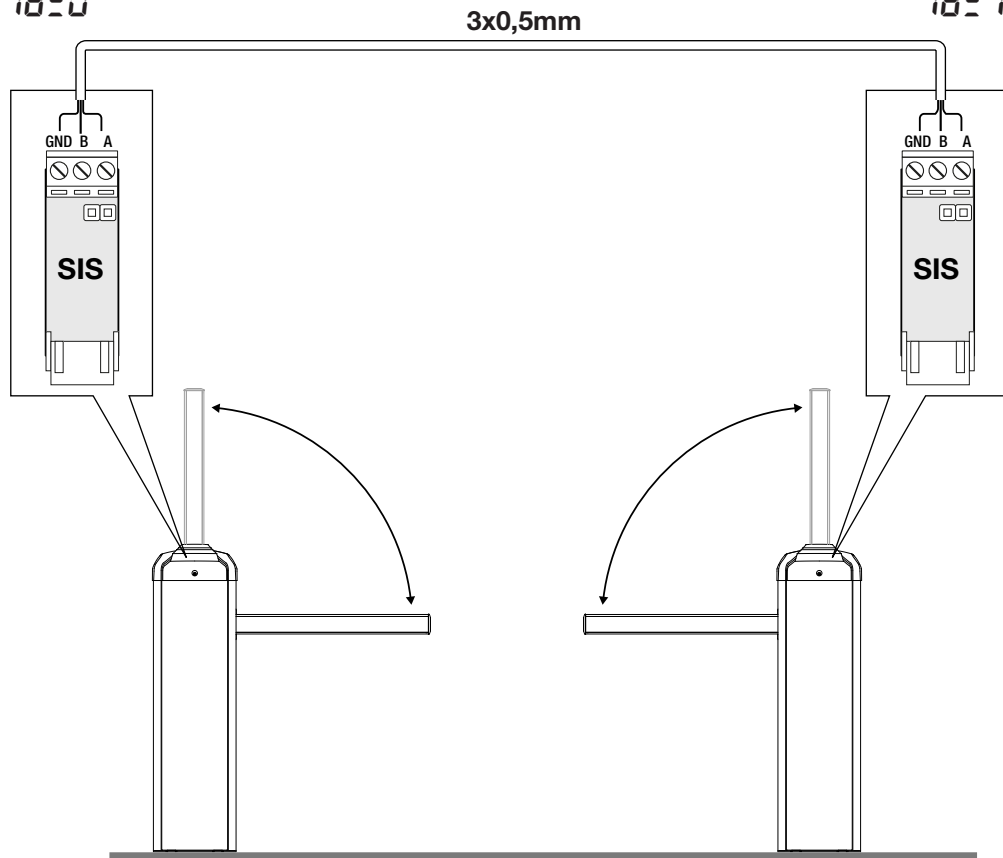

Schema menu di programmazione - Menu programming layout
 Diagramm Programmiermenü - Menu de programmation
 Menú de la carta de programación - Układ menu programowania

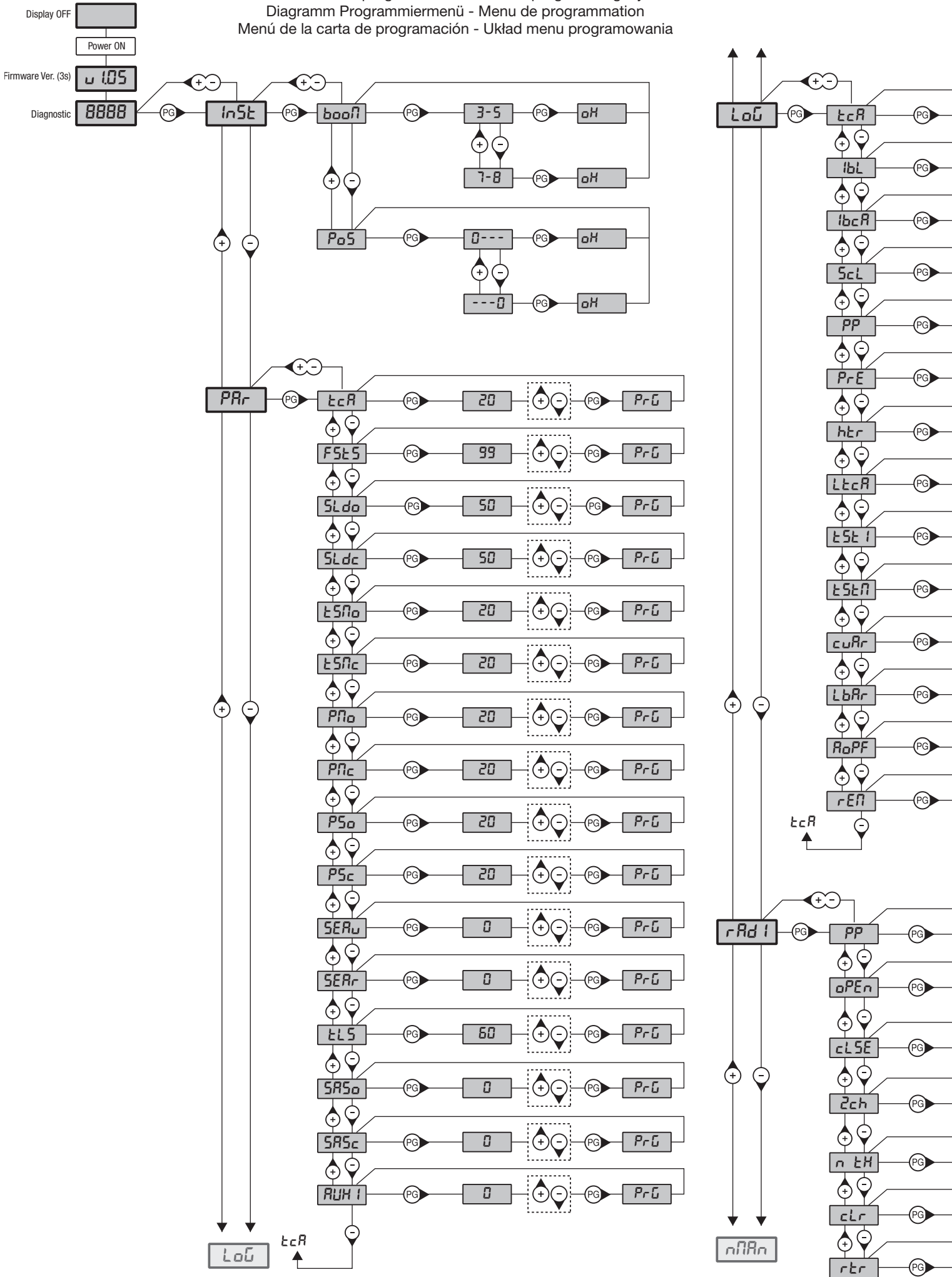

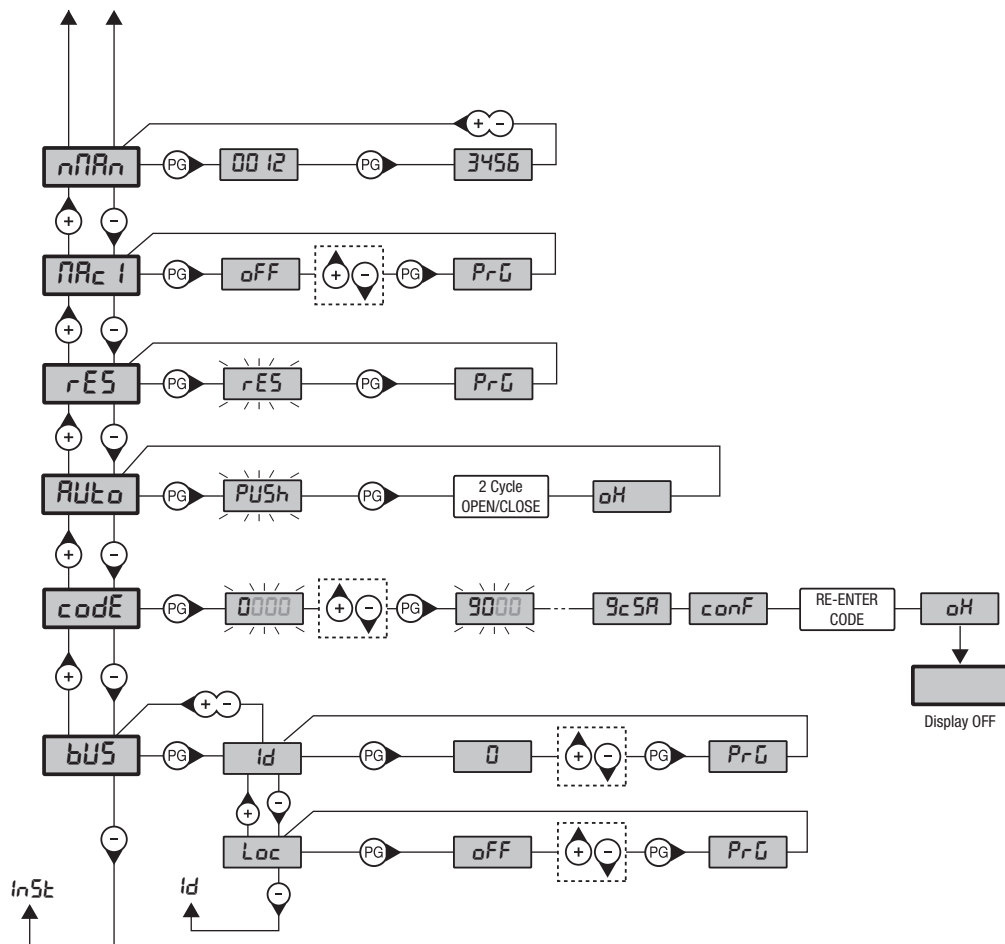
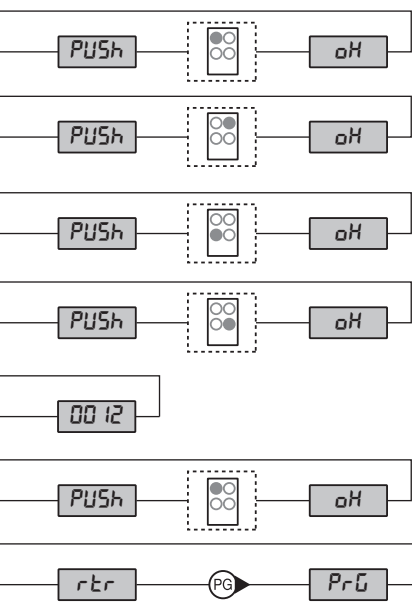
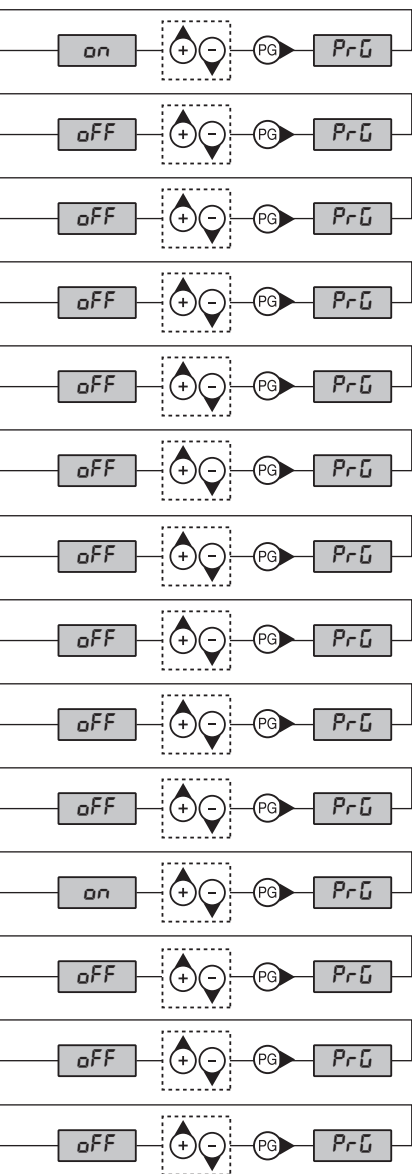

Legenda

	<p>Premere il tasto (-) / Press key (-) / Die Taste (-) drücken Appuyez sur la touche (-) / Presionar la tecla (-) / Wcisnąć przycisk (-)</p>
	<p>Premere il tasto (+) / Press key (+) / Die Taste (+) drücken Appuyez sur la touche (+) / Presionar la tecla (+) / Wcisnąć przycisk (+)</p>
	<p>Premere il tasto (PG) / Press key (PG) / Die Taste (PG) drücken Appuyez sur la touche (PG) / Presionar la tecla (PG) / Wcisnąć przycisk (PG)</p>
	<p>Premere simultaneamente (+) e (-) / Press simultaneously keys (+) and (-) Gleichzeitig (+) und (-) drücken / Presser simultanément (+) et (-) Presionar simultáneamente (+) y (-) / Naciskać jednocześnie (+) i (-)</p>
	<p>Selezionare il valore desiderato con i pulsanti (+) e (-) Increase/decrease the value with keys (+) and (-) Mit den Tasten (+) und (-) kann man eingerichtete Werte ändern Régler la valeur désirée avec les touches (+) et (-) Establecer con las teclas (+) y (-) el valor deseado Nastawia przyciskami (+) i (-) obraną wartość</p>
	<p>Selezionare il pulsante del trasmettitore da associare alla funzione Press the transmitter key, which is to be assigned to function Taste des Sendegeräts drücken, dem diese Funktion zugeteilt werden soll. Appuyer sur la touche du transmetteur qu'e l'on désire affecter à cette fonction. Presionar la tecla del transmisor que se desea asignar a esta función. Wcisnąć przycisk nadajnika, który zamierza się skojarzyć z tą funkcją.</p>

INDEX

1) DESCRIPTION.....	21	13.3.1) INSTALLATION (<i>İnSt</i>)	23
2) DIMENSIONS.....	21	13.3.2) PARAMETERS (<i>PRr</i>)	24
3) ARC COMPATIBLE CONTROL UNIT	21	13.3.3) LOGICS (<i>LcÜ</i>)	24
4) OPENING (FIG.2)	21	13.3.4) RADIO (<i>rRd İ</i>)	25
5) LEFT-RIGHT BARRIER (FIG. 3/4)	22	13.3.5) CYCLES NUMBER (<i>nİRn</i>)	25
6) EMERGENCY MANUAL OPERATION (FIG.5)	22	13.3.6) MAINTENANCE CYCLES (<i>İRc İ</i>)	26
7) INSTALLATION OF THE OPTIONAL FOUNDATION PLATE VE.P650 (FIG.6)	22	13.3.7) RESET (<i>rEİ</i>)	26
8) SELECTION OF ACCESSORIES	22	13.3.8) AUTOSET (<i>Rİİc</i>)	26
9) HOW TO FIX THE BEAM (FIG.7)	22	13.3.9) PASSWORD (<i>codE</i>)	26
10) BALANCING (FIG.10)	22	13.3.10) SYNCHRONIZATION (<i>bİİ</i>)	26
11) HOW TO ADJUST THE MECHANICAL STOPPERS (FIG.13)	22	13.4) SYNCHRONIZATION OF TWO OPPOSED BARRIERS	26
12) WIRE DIAGRAM (FIG.14)	22	13.5) TRANSMITTERS REMOTE LEARNING	27
13) CP.EVA2 CONTROL UNIT	23	13.6) FUSES	27
13.1) WIRE DIAGRAM	23	13.7) BACK UP BATTERIES	27
13.2) PROGRAMMING	23	13.8) DIAGNOSTICS	27
13.2.1) TO ACCESS PROGRAMMING	23	13.9) ERROR MESSAGES	27
13.2.2) PROGRAMMING NOTES	23	14) MAINTENANCE	27
13.3) PARAMETERS, LOGICS AND SPECIAL FUNCTIONS	23		

ENG

WARNING



GENERAL INFORMATIONS

The product shall not be used for purposes or in ways other than those for which the product is intended for and as described in this manual. Incorrect uses can damage the product and cause injuries and damages.

The company shall not be deemed responsible for the non-compliance with a good manufacture technique of gates as well as for any deformation, which might occur during use. Keep this manual for further use.



INSTALLER GUIDE

This manual has been especially written to be use by qualified fitters. Installation must be carried out by qualified personnel (professional installer, according to EN 12635), in compliance with Good Practice and current code.

Make sure that the structure of the gate is suitable for automation.

The installer must supply all information on the automatic, manual and emergency operation of the automatic system and supply the end user with instructions for use.



GENERAL WARNINGS

Packaging must be kept out of reach of children, as it can be hazardous.

For disposal, packaging must be divided the various types of waste (e.g. carton board, polystyrene) in compliance with regulations in force.

Do not allow children to play with the fixed control devices of the product.

Keep the remote controls out of reach of children.

This product is not to be used by persons (including children) with reduced physical, sensory or mental capacity, or who are unfamiliar with such equipment, unless under the supervision of or following training by persons responsible for their safety.

Apply all safety devices (photocells, safety edges, etc.) required to keep the area free of impact, crushing, dragging and shearing hazard. Bear in mind the standards and directives in force, Good Practice criteria, intended use, the installation environment, the operating logic of the system and forces generated by the automated system.

Installation must be carried out using safety devices and controls that meet standards EN 12978 and EN 12453.

Only use original accessories and spare parts, use of non-original spare parts will cause the warranty planned to cover the products to become null and void.

All the mechanical and electrical parts composing automation must meet the requirements of the standards in force and outlined by CE marking.



ELECTRICAL SAFETY

An omnipolar switch/section switch with remote contact opening equal to, or higher than 3mm must be provided on the power supply mains. Make sure that before wiring an adequate differential switch and an overcurrent protection is provided.

Pursuant to safety regulations in force, some types of installation require that the gate connection be earthed. During installation, maintenance and repair, cut off power supply before accessing to live parts.

Also disconnect buffer batteries, if any are connected.

The electrical installation and the operating logic must comply with the regulations in force. The leads fed with different voltages must be physically separate, or they must be suitably insulated with additional insulation of at least 1 mm.

The leads must be secured with an additional fixture near the terminals.

During installation, maintenance and repair, interrupt the power supply before opening the lid to access the electrical parts

Check all the connections again before switching on the power. The unused N.C. inputs must be bridged.



WASTE DISPOSAL

As indicated by the symbol shown, it is forbidden to dispose this product as normal urban waste as some parts might be harmful for environment and human health, if they are disposed of incorrectly.

Therefore, the device should be disposed in special collection platforms or given back to the reseller if a new and similar device is purchased.

An incorrect disposal of the device will result in fines applied to the user, as provided for by regulations in force.

Descriptions and figures in this manual are not binding. While leaving the essential characteristics of the product unchanged, the manufacturer reserves the right to modify the same under the technical, design or commercial point of view without necessarily update this manual.

QUICK PROGRAMMING

- Press the <PG> button, the display goes to the "INST" menu
 - Enter the INST menu
 - Verify that the parameter BOOM is correct: 3-5 for EVA.5, 7-8 for EVA.8
 - Set the barrier position by means of the menu POS, by default the barrier is set as RIGHT BARRIER
 - Enter the menu AUTO, confirm with <PG> and wait until the barrier has carried out the autose of the parameters
 - By means of the menus PAR and LOG, select the parameters and the logic functions wanted according to the type of installation in object
- IMPORTANT:** After every change of the parameters FSTS, SLDO, SLDC, TSMO, TSMC, the barrier executes an opening maneuver followed by a closing one in order to acquire the new values of current and torque, on the screen will appear the message <PRG>

EN

1) DESCRIPTION

Road barrier for passages up to 8m provided with built in control unit CP.EVA2 and quick external release for manual maneuver. It is possible the synchronization of 2 motors for controlling 2 opposed barriers, to do this it is necessary to use the synchronization control unit SIS (optional). Wire each other the two control units as shown in figure 14 and configure them as described in the paragraph "Synchronization of two opposed barriers". In addition to this it is possible the connection of two backup batteries by 12V 2,1Ah (DA.BT2), as shown in figure 14. The barrier can work also in absolute absence of power supply by means of the accessory KSUN (sun system composed by solar panel, backup batteries and control unit). Every utilization different from the one described in this instruction manual is not allowed and voids the manufacturer warranty.

We would like to remind you that if you register on the site www.beninca.com you will have access to the technical documentation updated for all the Beninca products and accessories and the guide for compiling the technical file and documents required under Annex V of the Machinery Directive, mandatory under the regulations in force.

IMPORTANT: whether the barrier is used even for pedestrian passage it is compulsory to carry out the force test as indicated by the European standard EN12445 (see the limitations as per the standard EN12453).

In case the passage is for vehicular use only, it is necessary to foresee appropriate signs of pedestrian prohibition.

2) DIMENSIONS

In figure 1 are shown the main dimensions of the EVA.8 barrier.

Overall dimensions are expressed in mm.

The road barrier length ranges from 7m minimum to 8m maximum.

As about 30cm are required to fix a road barrier, a useful opening of passage, ranging from 6,70m to 7,70m, will be available, as shown in Fig.1 Optional accessories can be fitted onto be barrier (photocells, selector, etc.). For assembly, apply the special covers supplied (Rif. A).

SPECIFICATION	EVA.8
Power supply	100-250 Vac 50/60Hz
Motor power supply	24Vdc
Power drawn	310 W
Current absorption	1,6 A
Stand by current absorption	40 mA (230 Vac - 50 mA (115 Vac)
Torque	285 Nm
Opening time	from 3,5 to 5 sec
Jogging	Intensive use
Protection class	IP44
Operating temperature	-20°C / +50°C
Noise	<70 dB
Lubrication	Agip GR MU EP/2
Weight	105kg

3) ARC COMPATIBLE CONTROL UNIT

IMPORTANT, PLEASE READ CAREFULLY:

The radio receiver in this product is compatible with the new ARC (Advanced Rolling Code) transmitters which, thanks to 128-bit encryption ensure superior copy-security.

Storing new ARC transmitters is quite similar to that of normal rolling code transmitters with HCS coding, but be aware that:

- 1) ARC transmitters and Rolling Code HCS can not be stored in a single receiver.
- 2) The first transmitter memorized determines the type of transmitters to be used later. If the first transmitter memorized is ARC, you can not store Rolling code HCS transmitters, and vice versa.
- 3) Fixed code transmitters may only be used in conjunction with Rolling code HCS transmitters, bringing the logic CVAR OFF. They are, therefore, not usable in combination with the ARC transmitters. If the first rolling code transmitter stored is an ARC CVAR the logic is inoperative.
- 4) If you want to change the type of transmitters it is necessary to proceed with a receiver reset.

4) OPENING (FIG.2)

The access to the electric and mechanical components of the road barrier is protected by a lock with customized key. Proceed as follows:

- 1 loosen the two nuts D
- 2 introduce the key in the lock on the side of the door and turn it anti-clockwise
- 3 lift the front cover
- 4 remove the cover

By removing the front door it is now possible to reach both the control unit, that is placed under the cover, and the mechanical parts of the road barrier.

5) LEFT-RIGHT BARRIER (FIG. 3/4)

The EVA.8 normally is provided as right barrier (Fig. 3 A : EVA.8 RIGHT)

Conventionally it is considered right a barrier which seen from the side of the cabinet door, closes the passage by lowering the boom towards right. However it is possible to reverse the barrier movement and turn a right barrier into a left one by means of few easy operations (Fig. 3 B : EVA.8 LEFT). If the opening direction reversion is required, proceed as follows. If it is not necessary, go to the next section:

- totally unload the springs by loosening them and unhook them from the anchoring lever "L" (fig. 4)
- remove screws D1 and D2 and fix the extension rod A in the opposite position, on lever V.
- remove and fix the extension lever R in the opposite position.
- fix the springs onto the anchoring lever "L" .
- Fig. 4 shows the different positions of the components shows the differences between a right-hand road barrier and a left-hand one.

ATTENTION: AN INVERSION OF THE OPENING DIRECTION IMPLIES THE MODIFICATION OF THE POS MENU, AS DESCRIBED IN THE PARAGRAPH "PROGRAMMING OF THE CONTROL UNIT".

6) EMERGENCY MANUAL OPERATION (FIG.5)

Should a power failure occur or in the event of faults in the system, the beam can be released and moved by hand:

- Introduce the customized key in the release lever and turn it clockwise.
- Turn the release lever anti-clockwise until the beam is released and it can be opened and closed by hand.
- To reset the automatic operation, turn the lever clockwise until the beam is released. Reset the initial position.

7) INSTALLATION OF THE OPTIONAL FOUNDATION PLATE VE.P650 (FIG.6)

After preparing the cable laying (mains power supply, accessories, etc.), place the foundation plate keeping to dimensions indicated.

Brackets to be cemented are supplied with the VE.P650 plate (ref. S). The brackets must be fitted to the foundation plate by means of 4 screws M12x50 (ref. V).

Check that the foundation plate is perfectly flat (ref. L), then fix the road barrier by means of nuts D and corresponding washers R.

Notes: the special shape of the slots on the bottom of the barrier cabinet, allow to adjust finely the position of the barrier.

It is suggested to leave 30 mm of threaded bar out from the foundation plate, a bigger length could generate an interference with the spring, a smaller length does not ensure the proper fixing of the barrier.

8) SELECTION OF ACCESSORIES

ROD LENGTH	USABLE ACCESSORIES
8 m	
7 m	VE.RAST
	SC.RES
	VE.RAST + VE.AM
	SC.RES + VE.AM

9) HOW TO FIX THE BEAM (FIG.7)

Any accessories for the beam (protection edges, lights, pneumatic safety edges, rack, etc.) are installed before fitting the beam. See relevant instructions.

Fit the beam to plate P by using bracket S and both the 6 screws with the corresponding washers, and plate T.

Apply the removable plastic cover C.

10) BALANCING (FIG.10)

For a good operation of road barrier, the beam must be suitable balanced by the spring.

To check the correct balancing, proceed as follows:

- Mechanically release the road barrier through the release key.
- The road beam, correctly balanced at approx. 45° , should remain still in any position:
 - if it tends to open, reduce the spring tension
 - if it tends to close, increase the spring tension

The spring tension can be adjusted by tightening (anti-clockwise rotation) or loosening (clockwise rotation) the spring by hand. Once the spring tension is adjusted, lock it by moving the nut "D" in contact with cap T.

11) HOW TO ADJUST THE MECHANICAL STOPPERS (FIG.13)

After the motor stop, the inertial movement of the beam is blocked thanks to adjustable mechanical stoppers.

By taking Fig.11 as a reference:

- Loosen locking screws V1 and V2.
- Tighten/loosen the mechanical stoppers F1 and F2 until the desired activation position is obtained.
- Fix screws V1 and V2.

12) WIRE DIAGRAM (FIG.14)

This figure shows an installation example of road barrier with its main accessories.

KEY

1. Control unit CP.EVA2
2. Receiver photocell FTC.S
3. Transmitter photocell FTC.S
4. Emergency batteries that can be installed inside the container of the control unit DA.BT2
5. EVA.LAMP flashing light card
6. Safety edge resistive type (8K2)
7. Control unit for safety edge management SC.EN
8. Blinking lights LADY.L

To install and connect the various accessories, see related instructions.

13) CP.EVA2 CONTROL UNIT

13.1) WIRE DIAGRAM

Wire connections shown in Fig. 13 are described hereunder:

TERMINAL BLOCK M3		
TERMINALS	Function	Description
ANT-SHIELD	Antenna	Connection for the antenna of the built in receiver (ANT-signal/SHIELD-shield). In case of use of an external antenna it is necessary to remove the pre-cabled cable from the terminal ANT
AUX	Auxiliary output AUX 1	Output with N.O. contact configurable by means of the logic AUX 1
24V	24 Vdc	Accessory power supply 24Vdc 500 mA maximum
MOT	Motor	Motor connection: 24Vdc.
TERMINAL BLOCK M2		
P.P.	Step by step	Input for step by step command (N.O. contact) .
CLOSE	Close	Input for close command (N.O. contact) .
OPEN	Open	Input for open command (N.O. contact), It is possible to connect a timer for programmed openings.
PHOT	Photocell	Input for photocells enabled during opening and closing phase (N.C. contact).
STOP	STOP	Input for STOP command (N.C. contact).
SWC	Closing limit switch	Input for closing limit switch (N.C. contact). To be used ONLY FOR BARRIER WITH ELECTROMECHANICAL LIMIT SWITCHES. If not used it is NOT NECESSARY TO BRIDGE the input to the common COM.
SWO	Opening limit switch	Input for opening limit switch (N.C. contact). To be used ONLY FOR BARRIER WITH ELECTROMECHANICAL LIMIT SWITCHES. If not used it is NOT NECESSARY TO BRIDGE the input to the common COM.
COM	Common	Common for all the input commands and the limit switches .
AUX2	24Vdc output for bar light	24Vdc output for the bar flashing light EVA.L (max 2), the flashing mode can be set by means of the logic LBAR.
BLINK	Blinker	Output 24Vdc 15W max. for flashing light connection (EVA.LAMP) to be installed on the top cover of the barrier.
TERMINAL BLOCK MENC		
ABS ENC	Encoder input	Absolute encoder input, pre-cabled by factory.
TERMINAL BLOCK M1		
M1	24Vdc INPUT	24Vdc input for powering the CP.EVA2. In case of use of the SUN SYSTEM it is necessary to connect the 24Vdc output of the SUN.SY to M1 (see the KSUN instructions)

13.2) PROGRAMMING

The programming of the various functions of the control unit is carried out using the LCD display on the control unit and setting the desired values in the programming menus described below.

The parameters menu allows you to assign a numerical value to a function, in the same way as a regulating trimmer.

The logic menu allows you to activate or deactivate a function, in the same way as setting a dip-switch.

13.2.1) TO ACCESS PROGRAMMING

- 1 - Press the <PG> button to enter the first Installation menu "INST".
- 2 - Choose with <+> or <-> button the menu you want to select
- 3 - Press the button <PG>, the display shows the first function available on the menu.
- 4 - With the <+> or <-> button, select the function you want.
- 5 - Press the button <PG>, the display shows the value currently set for the function selected.
- 6 - With the <+> or <-> button, select the value you intend to assign to the function.
- 7 - Press the button <PG>, the display shows the signal "PRG" which indicates that programming has been completed.

13.2.2) PROGRAMMING NOTES

Simultaneously pressing <+> and <-> from inside a function menu allows you to return to the previous menu without making any changes. Hold down the <+> key or the <-> key to accelerate the increase/decrease of the values.

Hold down the <+> key or the <-> key to accelerate the increase/decrease of the values.





After waiting 120s the control unit quits programming mode and switches off the display.

When the board is switched on, the software version is displayed for around 5 sec

The pre-set logic functions and parameters are made taking account of a typical installation.

13.3) PARAMETERS, LOGICS AND SPECIAL FUNCTIONS

The following tables describe the functions available on the control unit

13.3.1) INSTALLATION (Inst)			
MENU	FUNCTION	MIN-MAX-(Default)	MEMO
boom	Select the length of the boom installed on the barrier. Value expressed in meter from 3m to 5m (EVA5) or from 7m to 8m (EVA8) According to the selected boom length, the optimal value of speed will be set.	3/5 -7/8 (7-8)	
Pos	Set the closing direction of the barrier (see fig. 2) The symbol  --- indicates right barrier (R/RIGHT) DEFAULT The symbol ---  indicates left barrier (L/LEFT) Verify the opening direction of the boom and in case reverse it. Every change of this function automatically implies the starting of a new AUTOSET procedure.	 --- = RIGHT ---  = LEFT (RIGHT)	

13.3.2) PARAMETERS (PRr)			
MENU	FUNCTION	MIN-MAX-(Default)	MEMO
tCA	Automatic closing time. Enabled only with logic "TCA"=ON. At the end of the set time, the control unit commands a closing maneuver .	1-240-(20s)	
FSLS	Adjusts the opening and closing speed of the barrier (standard speed, before the slowdown phase).	50-99-(99)	
SLdo	Adjusts the slowdown speed of the barrier during the opening phase* (Fig.11 -slow Open).	20-70-(50)	
SLdc	Adjusts the slowdown speed of the barrier during the closing phase * (Fig.12 -slow Close).	20-70-(50)	
tSNo	Sets the starting point of the slowdown during the opening phase (Fig.11- beginning of the slow Open). The value is expressed in percentage on the entire stroke.	1-99-(20)	
tSnc	Sets the starting point of the slowdown during the closing phase (Fig.12- beginning of the slow Close). The value is expressed in percentage on the entire stroke.	1-99-(20)	
PNo	Adjusts the motor torque applied to the barrier during the opening phase.*	1-99-(20)	
Pnc	Adjusts the motor torque applied to the barrier during the closing phase.*	1-99-(20)	
PSo	Adjusts the motor torque applied to the barrier during the slowdown in opening phase * (Fig.10 - Slow Open).	1-99-(20)	
PSc	Adjusts the motor torque applied to the barrier during the slowdown in closing phase * (Fig.11 - Slow Close).	1-99-(20)	
SEAU	Adjusts the intervention threshold of the anti crushing device (Encoder) during the normal speed*. 0:Off -1: minimum sensitivity - 99: maximum sensitivity	0-99-(0%)	
SEAr	Adjusts the intervention threshold of the anti crushing device (Encoder) during the slowdown speed*. 0:Off -1: minimum sensitivity - 99: maximum sensitivity	0-99-(0%)	
tLS	Activation time of the courtesy light contact. Value expressed in seconds. At the beginning of each maneuver the contact latches for the set time. See the description of AUX1 parameter.	1-240 (60)	
SASo	Sets a short reversion after reaching the limit switch in open position. Can be useful for facilitating the manual release.	0-5 (0)	
SASc	Sets a short reversion after reaching the limit switch in close position. Can be useful for facilitating the manual release.	0-5 (0)	
AUX 1	Selects the functioning mode of the auxiliary output 1 (N.O. clean contact) 0: Open barrier light, close contact when the barrier is open, open contact when the barrier is close, intermittent during the maneuver (fig. 14, SCA) 1: Second radio channel of the built in receiver 2: Boom light, for controlling the LED light installed on the BOOM (EVA.LED), see also the parameter LBAR. 3: Courtesy light, the contact remains close according to the parameter TLS (fig.14 SERVICE LIGHT) 4: Photocells test, see wiring diagram in Fig.14 (PHOTOTEST) 5: Close contact with open barrier 6: Close contact with close barrier	0-6-(0)	
* ATTENTION: A WRONG SETTING OF THESE PARAMETERS CAN BE DANGEROUS. RESPECT THE REGULATION IN FORCE!			

13.3.3) LOGICS (LdL)			
MENU	FUNZIONE	ON-OFF-(Default)	MEMO
tCA	Enables or disables automatic closing On: automatic closing enabled Off: automatic closing disabled	(ON)	
IBL	Enables or disables condominium function. On: condominium function enabled. The step-by-step impulse or transmitter impulse has no effect during the opening phase. Off: condominium function disabled.	(OFF)	
IBcA	The multi-flat function is enabled or disabled during the TCA counting. On: the bloc of flat function is enabled. The Step-by-Step signal or the transmitter signal has no effect during the TCA counting. Off: the bloc of flat function is disabled.	(OFF)	
SCL	Enables or disables rapid closing On: rapid closure is enabled. With open bar, or in the opening phase, the activation of the photocell causes the automatic closure 3sec after the total opening of the gate. It is activated only with TCA:ON Off: rapid closing disabled.	(OFF)	
PP	Selects the operating mode of the "Step by step button" and of the transmitter. On: Operation: OPEN > CLOSE > OPEN > Off: Operation: OPEN > STOP > CLOSE > STOP >	(OFF)	
PrE	Enables or disables pre-blinking. On: Pre-blinking enabled. Blinking is activated 3s before the motor starts. Off: Pre-blinking disabled.	(OFF)	

htr	Enabled or disables HOLD-TO-RUN function On: HOLD-TO-RUN function. The pressure of the OPENS/CLOSES button must be maintained throughout the entire manoeuvre. The opening of the STOP input stops the motor. All the safety inputs are deactivated. Off: Automatic/semiautomatic function	(OFF)	
LtCA	Selects the operating mode of the blinking light during the time TCA On: Blinking light on during TCA Off: Blinking light off during TCA	(OFF)	
tSt1	Enables or disables checking of photocells on PHOT input, active both in closing and in opening. On: Check enabled. If the check has a negative result, no manoeuvre is commanded. See Fig.14 - "PHOTO TEST". Off: Checking of photocells disabled at each manoeuvre.	(OFF)	
tStn	Enables or disables motors check. On: Check enabled. If the check has a negative result, no manoeuvre is commanded. Off: Check disabled.	(OFF)	
cuAr	Enables or disables the programmable code transmitters. IMPORTANT: The transmitters with programmable code can only be used in conjunction with the Rolling Code HCS transmitters. On: Radio receiver enabled only for transmitters Rolling Code (ARC or HCS, the first transmitter sets the operating mode). Off: Receiver enabled for transmitters Rolling Code HCS and programmable (selflearning and dip/switch).	(ON)	
LbAr	Selects the functioning mode of the boom light (24Vdc output on AUX2 or N.O. contact on the output AUX 1 when configured at 2). On: The boom light is off when the barrier is close, it turns on when the barrier is in movement or open. Off: The boom light flashes slowly when the barrier is open or close (1s pause), it flashes quickly (0,5s pause) when the barrier is in movement.	(OFF)	
RoPF	The "forced opening in case of power cut-off" function is activated or deactivated (it can be activated only with connected and operating emergency batteries). On: Activated function. In the event of power failure, the control unit causes an opening operation. The barrier remains open until the power supply is back. Off: Deactivated function.	(OFF)	
rEn	Enables or disables remote radiotransmitters learning, as indicated in the paragraph "Remote transmitters learning". On: Remote learning enabled. Off: Remote learning not enabled.	(OFF)	

13.3.4) RADIO (rRd !)

MENU	FUNZIONE
pp	By selecting this function, the receiver goes in waiting (PUSH) for a transmitter code to assign to the step-step function. Press the key of the transmitter to assign to this function. If the code is valid, it is memorised and the message oH is displayed If the code is not valid, the message Err is displayed
oPEn	By selecting this function, the receiver goes in waiting (PUSH) for a transmitter code to assign to the OPEN function. Press the key of the transmitter to assign to this function. If the code is valid, it is memorised and the message oH is displayed If the code is not valid, the message Err is displayed
cLoSE	By selecting this function, the receiver goes in waiting (PUSH) for a transmitter code to assign to the CLOSE function. Press the key of the transmitter to assign to this function. If the code is valid, it is memorised and the message oH is displayed If the code is not valid, the message Err is displayed
2ch	By selecting this function, the receiver goes into waiting (PUSH) for a transmitter code to assign to the second radio channel. Press the key of the transmitter to assign to this function. If the code is valid, it is memorised and the oH message is displayed If the code is not valid, the message Err is displayed.
nEtH	By selecting this function the LCD screen shows the number of transmitters memorized into the receiver.
clR	By selecting this function, the receiver goes into waiting (PUSH) for a transmitter code to erase from the memory. If the code is valid, it is erased and the message oH is displayed If the code is not valid or not present in memory, the message Err is displayed
rEr	Completely erases memory of the receiver. Confirmation of the operation is requested. By selecting this function the receiver goes into waiting (PUSH) for a new PGM pressure to confirm the operation. At end of erasing the oH message is displayed

13.3.5) CYCLES NUMBER (nRn)

Displays the number of complete cycles (open+close) carried out by the automation.

When the <PG> button is pressed for the first time, it displays the first 4 figures, the second time it shows the last 4. Example <PG> 00 12 >>> <PG> 3456: made 123.456 cycles.

13.3.6) MAINTENANCE CYCLES (MPC)

This function enables to activate the maintenance request notice after a number of manoeuvres determined by the installer. To activate and select the number of manoeuvres, proceed as follows:
Press button <PG>, the display will show OFF, which indicated that the function is disabled (default value).
With the buttons <+> and <-> select one of the numeric values proposed (from OFF to 100). The values are intended as hundreds of cycles of manoeuvres (for example: the value 50 indicates 5000 manoeuvres).
Press the OK button to activate the function. The display will show the message *Prog.*
The maintenance request is indicated to the user by keeping the indicator lamp lit up for other 10 sec after the conclusion of the opening or closing operation.

13.3.7) RESET (RE5)

RESET of the control unit. ATTENTION!: Returns the control unit to the default values.
Pressing the <PG> button for the first time causes blinking of the letters RE5, pressing the <PG> button again resets the control unit. Note: The transmitters are not erased from the receiver nor is the access password.
All the logics and all the parameters are brought back to default values, it is therefore necessary to repeat the autose procedure.

13.3.8) AUTOSET (AUTO)

This function sets the optimal functioning values of the installation, at the end of the procedure, it sets the average values of torque (PMO/PMC and PSO/PSC). To carry out the AUTOSET, proceed as follow:
a) Make sure that during the autose there is no obstacle in the maneuver area, if necessary, fence off the area so that persons, animals, cars, etc., cannot interrupt the procedure.
During the AUTOSET procedure, the anti crushing feature is not enabled.
b) select the function AUTO and press PG.
c) the control unit waits the confirmation to start the procedure "PUSH"
c) press PG to start the AUTOSET procedure.
The control unit performs few maneuvers for the stroke learning and the configuration of the parameters.
In case that the procedure is not successful the message ERR will be shown. Repeat the procedure after checking the wirings and the possible presence of obstacles.
The control unit recognizes automatically the presence of the absolute encoder, electromechanical limit switches or mechanical stops during the AUTOSET procedure. In case of use with encoder or mechanical stops do not link the inputs SWO-SWC to the common.

13.3.9) PASSWORD (CODE)

It allows to type in an access protection code to the programming of the control unit.
A four-character alphanumeric code can be typed in by using the numbers from 0 to 9 and the letters A-B-C-D-E-F.
The default value is 0000 (four zeros) and shows the absence of a protection code.
While typing in the code, this operation can be cancelled at any moment by pressing keys + and - simultaneously. Once the password is typed in, it is possible to act on the control unit by entering and exiting the programming mode for around 10 minutes in order to allow adjustments and tests on functions.
By replacing the 0000 code with any other code, the protection of the control unit is enabled, thus preventing the access to any other menu. If a protection code is to be typed in, proceed as follows:
- select the Code menu and press OK.
- the code 0000 is shown, also in the case a protection code has been previously typed in.
- the value of the flashing character can be changed with keys + and -.
- press OK to confirm the flashing character, then confirm the following one.
- after typing in the 4 characters, a confirmation message "CONF" appears.
- after a few seconds, the code 0000 appears again
- the previously stored protection code must be reconfirmed in order to avoid any accidental typing in.
If the code corresponds to the previous one, a confirmation message "OK" appears.
The control unit automatically exits the programming phase. To gain access to the Menus again, the stored protection code must be typed in.
IMPORTANT: TAKE NOTE of the protection code and KEEP IT IN A SAFE PLACE for future maintenance operations.
To remove a code from a protected control unit it is necessary to enter into programming with the password and bring the code back to the 0000 default value.
IF YOU LOOSE THE CODE, PLEASE CONTACT THE AUTHORISED SERVICE CENTER FOR THE TOTAL RESET OF THE CONTROL UNIT.

13.3.10) SYNCHRONIZATION (ID5)

MENU	FUNZIONE
ID	Sets the synchronizing number. It is possible to set a numeric value from 0 to 16. If the ID parameter is to 0 the control unit is set as MASTER, all the other values set the barrier as SLAVE.
LOC	Allows a barrier set as SLAVE to receive local commands. See paragraph 12.4 "SYNCHRONIZATION OF TWO OPPOSED BARRIERS"

13.4) SYNCHRONIZATION OF TWO OPPOSED BARRIERS

It is possible to manage a system composed of two barriers by using for each CP.EVA2 the specific optional control unit SIS, which must be plugged into the appropriate connector as shown in Fig. 14.

Each SIS unit must be connected to the other one by means of 3 wires by 0,5 sq.mm each, as shown in Fig.15.

One of the control unit must be set as MASTER (ID=0) and the other one as SLAVE (ID>0).

All the commands (commands given by transmitters, push buttons or safety devices) received by the MASTER barrier are sent to the SLAVE barrier, which will replicate instantaneously the behavior of the MASTER.

The logic LOC can be set in two ways:

ON: the SLAVE barrier can accept a local command and execute an opening/closing maneuver with no effect on the MASTER barrier.

OFF: the SLAVE barrier do not accept any local command and so it will replicate exclusively the behavior of the MASTER barrier.

A SLAVE barrier with LOC set to ON can be useful in case it is occasionally necessary the partial opening of a passage which is usually managed by two synchronized barriers, since that a step by step command (or OPEN/CLOSE) given to the SLAVE will have effect only on this last one, while all the other commands given to the MASTER will be replicated by the SLAVE.

The connection of the safety devices (photocells, safety edges, etc.) can be done indifferently to the MASTER unit or to the SLAVE.

13.5) TRANSMITTERS REMOTE LEARNING

If an already memorised transmitter is available in the receiver it is possible to carry out remote radio learning (without needing to access the control unit). **IMPORTANT: the procedure must be carried out with barrier open. The logic REM must be ON.**

Proceed as follows:

- 1 Press the hidden key of the transmitter which is already memorised.
- 2 Press, within 5s, the key of the corresponding transmitter which is already memorised to associate to the new transmitter. The flashing light will turn on.
- 3 Press within 10s the hidden key of the new transmitter.
- 4 Press, within 5s, the key of the new transmitter to associate to the channel chosen at point 2. The flashing light will turn off.
- 5 The receiver memorised the new transmitter and immediately exits from programming.

13.6) FUSES

F3 CP.EVA2: T1A - Fuse for the protection of the accessories power supply
 F1 SA.24V: T4A - Fuse for general protection

13.7) BACK UP BATTERIES

The control unit CP.EVA2 includes the power pack SA.24V predisposed for the connection of two batteries by 12Vdc 2,1Ah DA.BT2 (optional) which guarantee the regular functioning of the automation in case of temporary power failure.
 When the barrier is working with mains voltage the power pack SA.24V charges the batteries (Fig. 13).
 The maximum charging current is 1A, the average charging current is 300 mA.

13.8) DIAGNOSTICS

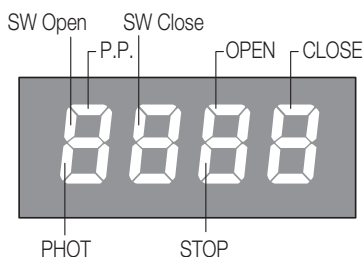

LED 1 : Presence of mains voltage
 LED 2 : Control unit CP.EVA2 correctly powered
 To each input is associated a line of the LCD screen which in case of activation it turns on according to the following diagram.
 The N.C. inputs are represented by vertical lines.
 The N.O. inputs are represented by horizontal lines.
 The flashing mode of the lines SW Open (when the barrier is open) and SW Close (when the barrier is close) indicates the type of limit switch used.
 2 flashes and pause: Presence of mechanical stops, no encoder, no electromechanical limit switches
 1 flash and pause: Absolute encoder version (standard)
 No flashing (always on) = Electromechanical limit switches

13.9) ERROR MESSAGES

Some messages that are displayed in case of function anomalies are listed as follows:

Err	Generic error	Error inserting password or memorizing transmitter..
Err 1	Motor error	Verify the motor wirings, faulty motor or not connected, problem on the control unit.
Err 2	Photocells error	Verify connections, photocells alignment and presence of obstacles.
Err 3	Absolute encoder error	Verify encoder connections, verify the good functioning of the Encoder.
RIP	Amperometric sensor intervention	Verify the presence of obstacles or friction points.
Thrn	Thermal sensor intervention	Overheating due to a too intensive use, wait the restoring.
ouLd	Overload	Exceeding of the maximum power. Verify the motor and presence of friction points..
Enc	Encoder	Encoder threshold intervention.

14) MAINTENANCE

The following table is used to record maintenance operations, improvement or repair works carried out by the expert engineer.

Date _____	Engineer's Signature _____	Stamp
Description of operation _____ _____ _____		
Date _____	Engineer's Signature _____	Stamp
Description of operation _____ _____ _____		
Date _____	Engineer's Signature _____	Stamp
Description of operation _____ _____ _____		

SAFETY MEASURES

- Do not stand within the gate movement area.
- Children must not play with controls and near the gate.
- In the event of malfunctions, do not attempt to repair the failure but contact the specialised personnel.

MANUAL AND EMERGENCY MANOEUVRE

Should a power failure occur or in the event of faults in the system, the beam can be released and moved by hand:

- Introduce the customized key in the release lever and turn it clockwise.
- Turn the release lever anti-clockwise until the beam is released and it can be opened and closed by hand.
- To reset the automatic operation, turn the lever clockwise until the beam is released. Reset the initial position.

MAINTENANCE

- Every month check the good operation of the emergency manual release.
- It is mandatory not to carry out extraordinary maintenance or repairs as accidents may be caused. These operations must be carried out by qualified personnel only.
- The operator is maintenance free but it is necessary to check periodically if the safety devices and the other components of the automation system work properly. Wear and tear of some components could cause dangers.

WASTE DISPOSAL



As indicated by the symbol shown, it is forbidden to dispose this product as normal urban waste as some parts might be harmful for environment and human health, if they are disposed of incorrectly. Therefore, the device should be disposed in special collection platforms or given back to the reseller if a new and similar device is purchased. An incorrect disposal of the device will result in fines applied to the user, as provided for by regulations in force.

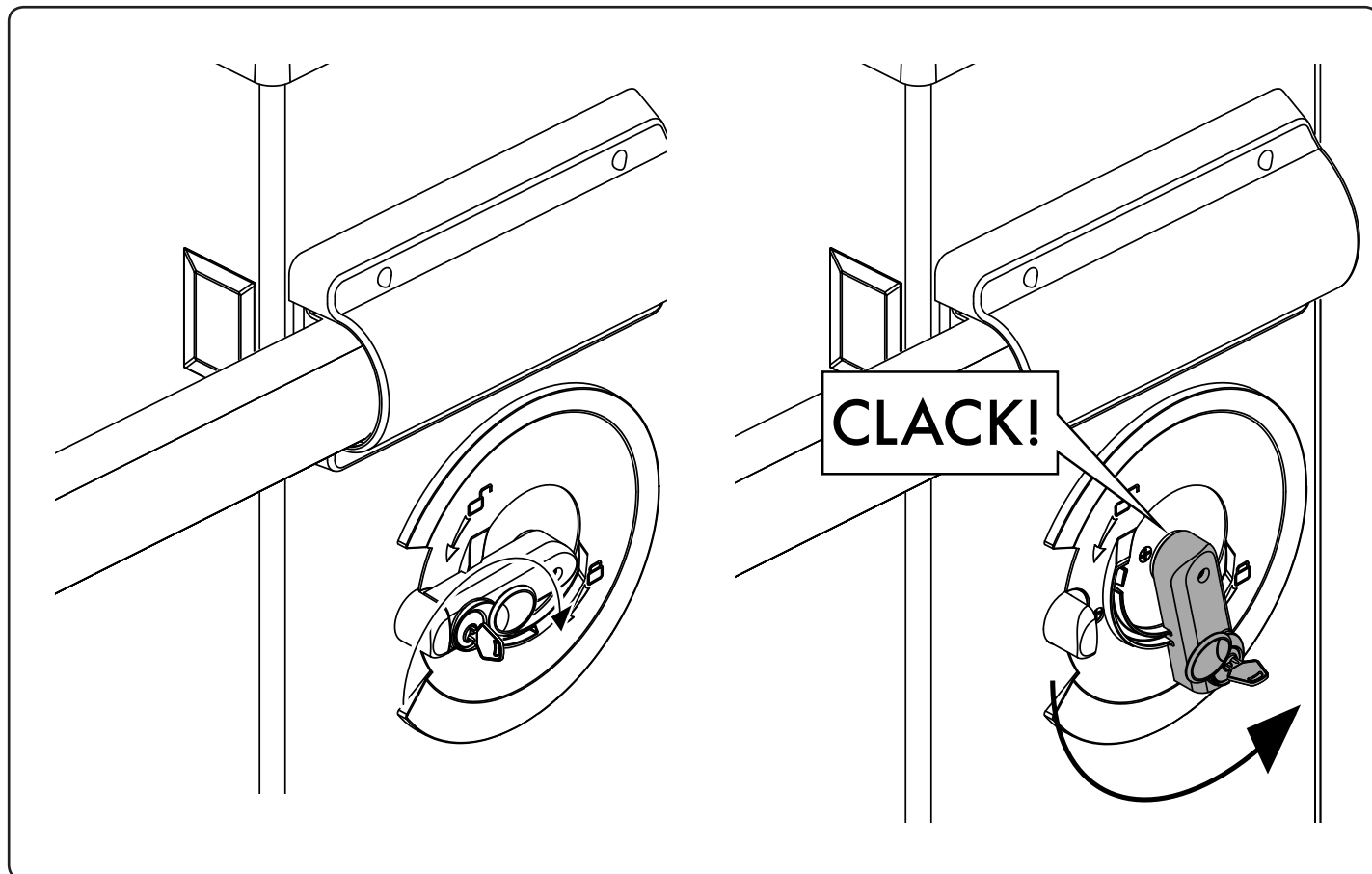

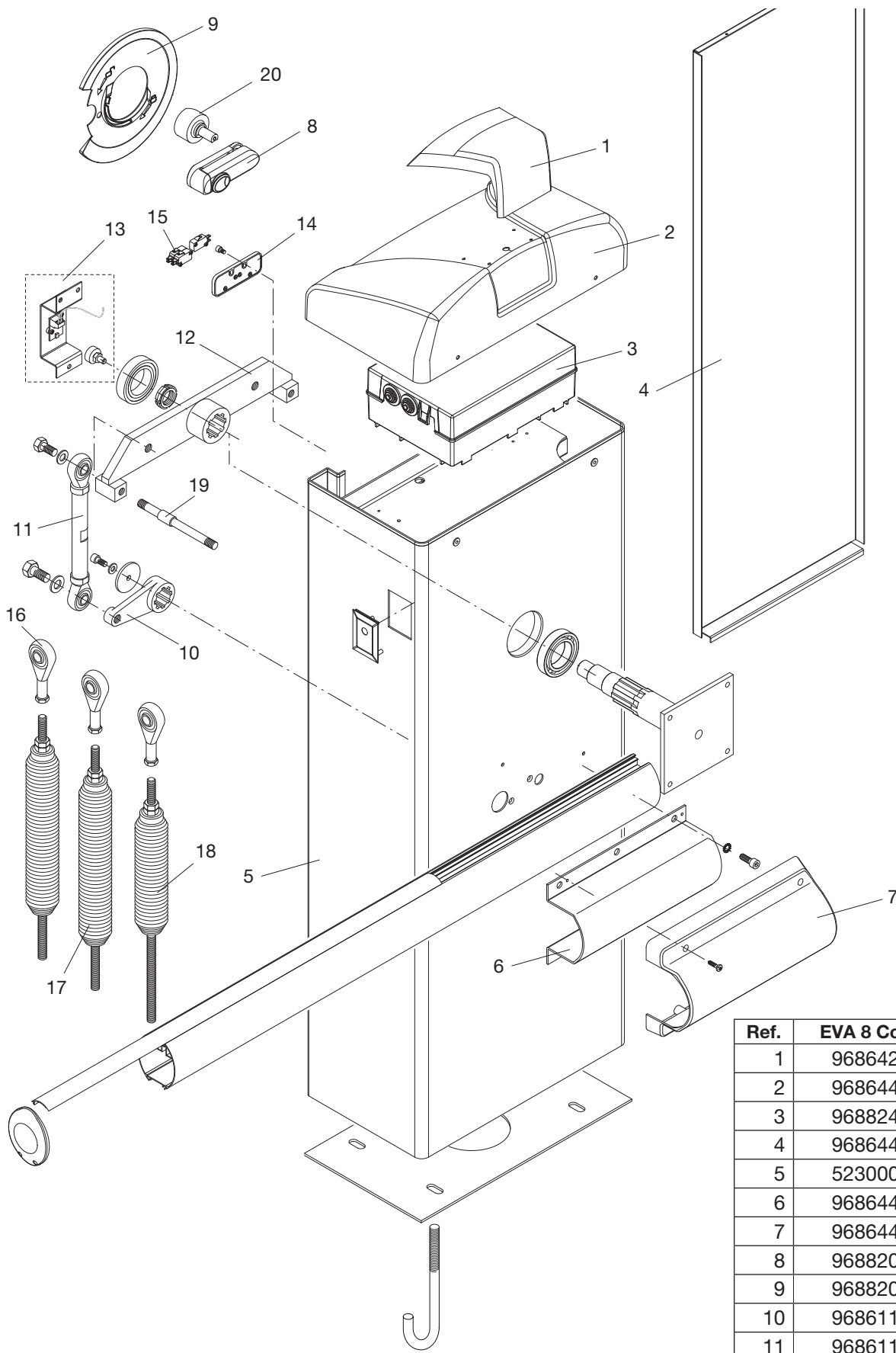

Ref.	EVA 8 Code	Note
1	9686428	
2	9686440	
3	9688240	
4	9686441	
5	5230003	
6	9686443	
7	9686444	
8	9688204	
9	9688205	
10	9686117	
11	9686115	
12	9686473	
13	9686160	
14	9686438	
15	9686120	
16	5780006	
17	9686517	1 pz (480mm)
18	9576001	1 pz (364mm)
19	F8262103	
20	9688213	

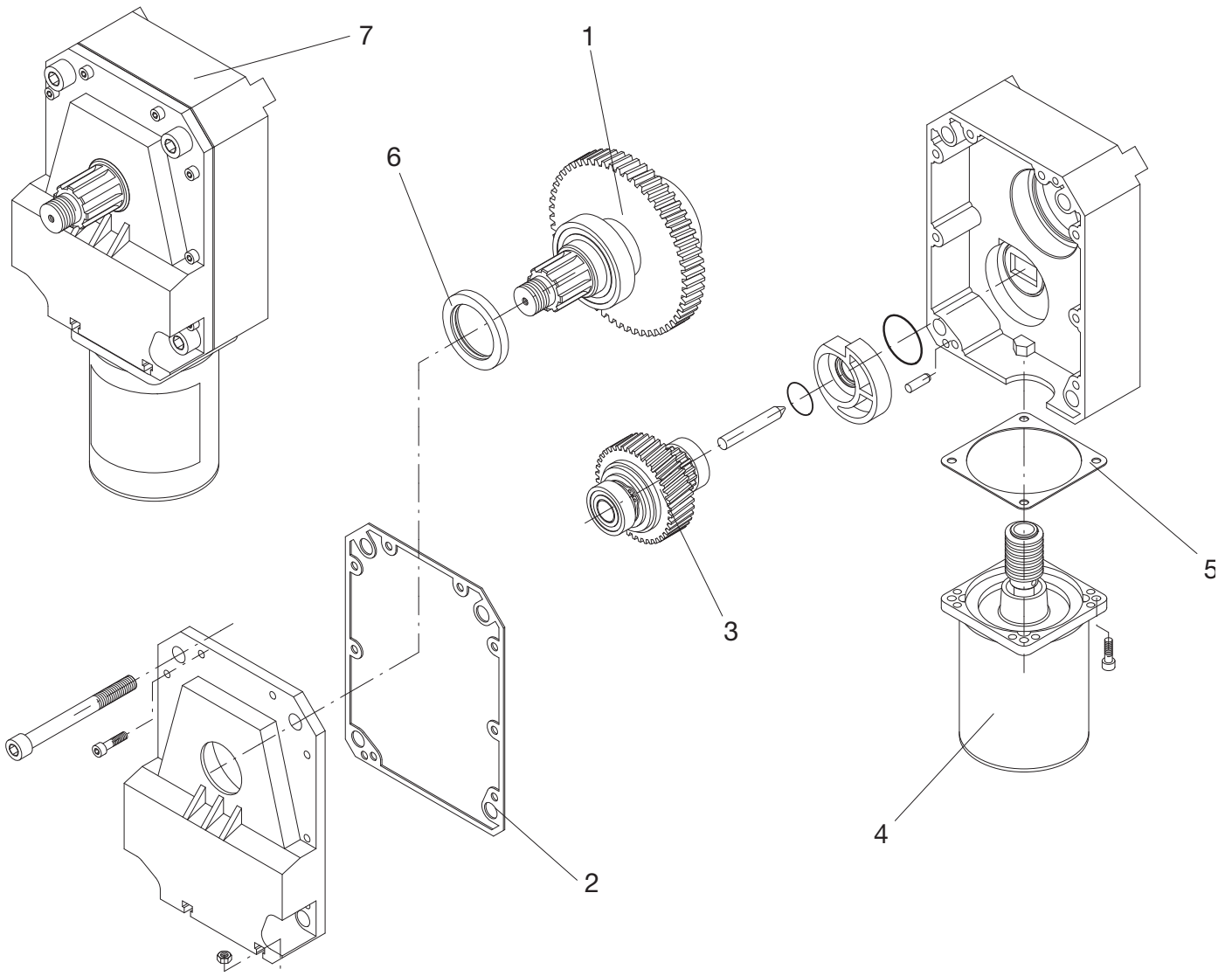

Ref.	EVA8 Code	Note
1	9686556	
2	9686112	
3	9686111	
4	9686107	
5	9686109	
6	9686555	
7	9688211	

Dichiarazione di Conformità UE (DoC)

Nome del produttore: **Automatismi Benincà SpA**
Indirizzo: **Via Capitello, 45 - 36066 Sandrigo (VI) - Italia**
Telefono: **+39 0444 751030** Indirizzo e-mail: **sales@beninca.it**
Persona autorizzata a costruire la documentazione tecnica: **Automatismi Benincà SpA**
Tipo di prodotto: **automazione per barriere stradali**
Modello/Tipo: **EVA.8**
Accessori: **N/A**

Il sottoscritto Luigi Benincà, in qualità di Responsabile Legale, dichiara sotto la propria responsabilità che il prodotto sopraindicato risulta conforme alle disposizioni imposte dalle seguenti direttive:

Direttiva 2014/30/UE del Parlamento europeo e del Consiglio, del 26 febbraio 2014, concernente l'armonizzazione delle legislazioni degli Stati membri relative alla compatibilità elettromagnetica (**EMCD**), secondo le seguenti norme armonizzate:
EN 61000-6-2:2005, EN 61000-6-3:2007.

Direttiva 2014/35/EU DEL PARLAMENTO EUROPEO E DEL CONSIGLIO del 26 febbraio 2014 concernente l'armonizzazione delle legislazioni degli Stati membri relative alla messa a disposizione sul mercato del materiale elettrico destinato ad essere adoperato entro taluni limiti di tensione (**LVD**), secondo le seguenti norme armonizzate:

EN 60335-1:2012 + A11:2014; EN 60335-2-103:2015.

Direttiva 2011/65/UE del Parlamento europeo e del Consiglio, dell'8 giugno 2011, sulla restrizione dell'uso di determinate sostanze pericolose nelle apparecchiature elettriche ed elettroniche (**RoHS**), secondo le seguenti norme armonizzate:

EN 50581:2012

Direttiva 1999/5/CE del Parlamento europeo e del Consiglio, del 9 marzo 1999, riguardante le apparecchiature radio e le apparecchiature terminali di telecomunicazione e il reciproco riconoscimento della loro conformità (**R&TTE**), secondo le seguenti norme armonizzate:

ETSI EN 301 489-3 V1.4.1 (2002) + ETSI EN 301 489-1 V1.4.1 (2002) +
ETSI EN 300 220-3 V1.1.1 (2000) + EN 60950-1 (2001)

Direttiva 2006/42/CE DEL PARLAMENTO EUROPEO E DEL CONSIGLIO del 17 maggio 2006 relativa alle macchine e che modifica la direttiva 95/16/CE, rispettando i requisiti per le "quasi macchine", secondo la seguente norma: EN13241-1:2003.

• Il produttore dichiara, inoltre, che la documentazione tecnica pertinente è stata compilata in conformità all'allegato VII B della direttiva 2006/42/CE e che sono stati rispettati i seguenti requisiti essenziali:

1.1.1 - 1.1.2 - 1.1.3 - 1.1.5 - 1.2.1 - 1.2.3 - 1.2.6 - 1.3.1 - 1.3.2 - 1.3.3 - 1.3.4 - 1.3.7 - 1.3.9 - 1.5.1 - 1.5.2 - 1.5.4 - 1.5.5 - 1.5.6 - 1.5.7 - 1.5.8 - 1.5.10 - 1.5.11 - 1.5.13 - 1.6.1 - 1.6.2 - 1.6.4 - 1.7.2 - 1.7.4 - 1.7.4.1 - 1.7.4.2 - 1.7.4.3.

• Il produttore si impegna a trasmettere alle autorità nazionali, in risposta ad una motivata richiesta, le informazioni pertinenti sulla "quasi macchina". L'impegno comprende le modalità di trasmissione e lascia impregiudicati i diritti di proprietà intellettuale del fabbricante della "quasi macchina".

• Si comunica che la "quasi macchina" non deve essere messa in servizio finché la macchina finale in cui deve essere incorporata non è stata dichiarata conforme, se del caso, alle disposizioni della direttiva 2006/42/CE.

• Inoltre il prodotto, limitatamente alle parti applicabili, risulta conforme alle seguenti norme:

EN 12445:2002, EN 12453:2002, EN 12978:2003.

Benincà Luigi, Responsabile legale.
Sandrigo, 15/02/2017.

Il Certificato di Conformità di questo documento corrisponde all'ultima revisione disponibile al momento della stampa e può risultare differente per esigenze editoriali dall'originale disponibile presso il produttore.

Il Certificato di Conformità più completo e recente è disponibile consultando il sito: www.beninca.com oppure può essere richiesto presso: Automatismi Benincà S.p.A - Sandrigo VI - Italy.

UE Declaration of Conformity (DoC)

Manufacturer's name: **Automatismi Benincà SpA**
Address: **Via Capitello, 45 - 36066 Sandrigo (VI) - Italia**
Telephone: **+39 0444 751030** Email address: **sales@beninca.it**
Person authorised to draft the technical documentation: **Automatismi Benincà SpA**
Product type: **operator for road gates**
Model/type: **EVA.8**
Accessories: **N/A**

The undersigned Luigi Benincà, as the Legal Officer, declares under his liability that the aforementioned product complies with the provisions established by the following directives:

Directive 2014/30/UE OF THE EUROPEAN PARLIAMENT AND OF THE COUNCIL of 26 February 2014, on the harmonisation of the laws of Member States relating to electromagnetic compatibility (**EMCD**), according to the following harmonised regulations:

EN 61000-6-2:2005, EN 61000-6-3:2007 + A1:2011.

Directive 2014/35/UE OF THE EUROPEAN PARLIAMENT AND OF THE COUNCIL of 26 February 2014, on the harmonisation of the laws of Member States relating to electrical equipment designed for use with certain voltage limits (**LVD**), according to the following harmonised regulations:

EN 60335-1:2012 + A11:2014; EN 60335-2-103:2015.

Directive 2011/65/EU of the European Parliament and Council, dated 8 June 2011, on the restricted use of certain hazardous substances in electrical and electronic devices (**RoHS**), according to the following standards:

EN 50581:2012

Directive 1999/5/CE OF THE EUROPEAN PARLIAMENT AND COUNCIL,

9 March 1999 in relation to radio equipment and telecommunications terminals and the mutual recognition of their conformity (**R&TTE**), per the following harmonised standards:

ETSI EN 301 489-3 V1.4.1 (2002) + ETSI EN 301 489-1 V1.4.1 (2002) +
ETSI EN 300 220-3 V1.1.1 (2000) + EN 60950-1 (2001)

Directive 2006/42/EC OF THE EUROPEAN PARLIAMENT AND OF THE COUNCIL of 17 May 2006, on machinery, which amends Directive 95/16/EC, and complies with the requisites for the "partly completed machinery (almost machinery)" set forth in the EN13241-1:2003 regulation.

• The manufacturer declares that the pertaining technical documentation has been drawn up in compliance with Attachment VII B of the 2006/42/ EC Directive and that the following requirements have been complied with:

1.1.1 - 1.1.2 - 1.1.3 - 1.1.5 - 1.2.1 - 1.2.3 - 1.2.6 - 1.3.1 - 1.3.2 - 1.3.3 - 1.3.4 - 1.3.7 - 1.3.9 - 1.5.1 - 1.5.2 - 1.5.4 - 1.5.5 - 1.5.6 - 1.5.7 - 1.5.8 - 1.5.10 - 1.5.11 - 1.5.13 - 1.6.1 - 1.6.2 - 1.6.4 - 1.7.2 - 1.7.4 - 1.7.4.1 - 1.7.4.2 - 1.7.4.3.

• The manufacturer undertakes that information on the "partly completed machinery" will be sent to domestic authorities. Transmission ways are also included in the undertaking, and the Manufacturer's intellectual property rights of the "almost machinery" are respected.

• It is highlighted that commissioning of the "partly completed machinery" shall not be provided until the final machinery, in which it should be incorporated, is declared compliant, if applicable, with provisions set forth in the Directive 2006/42/EC on Machinery.

• Moreover, the product, as applicable, is compliant with the following regulations:
EN 12445:2002, EN 12453:2002, EN 12978:2003

Benincà Luigi, Legal Officer.
Sandrigo, 15/02/2017.

The certificate of conformity in this document corresponds to the last review available at the time of printing and could differ for editorial requirements from the original available from the manufacturer.

The most recent and complete certificate of conformity is available consulting the site: www.beninca.com or can be requested from: Automatismi Benincà SpA - Sandrigo VI - ITALY.

TIPS & TRICKS

BOOM GATE INSTALLATION



General order of installation –

1. Boom gates generally have three distinct install phases. The first is preparation - running your cables and preparing your hardstand. All accessories cables (except loops) should be shielded cable.
2. Your hardstand ideally will be 300mm wider and longer than the boom gate base and a good 600mm deep to prevent the boom gate from moving during operation. If the hardstand is new it is good practice and makes stage two a breeze if you use a base plate.
3. Stage two involves bolting down the boom gate and getting it balanced. Do NOT connect any accessories attempt to program or run the boom gate until the boom gate is balanced.

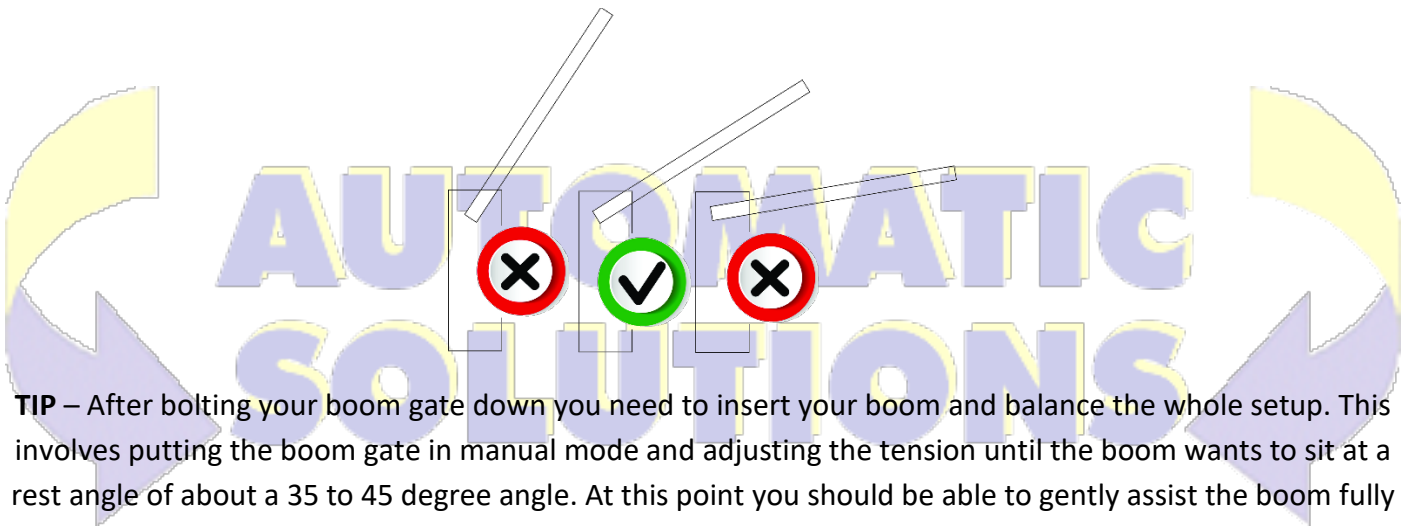

TIP – After bolting your boom gate down you need to insert your boom and balance the whole setup. This involves putting the boom gate in manual mode and adjusting the tension until the boom wants to sit at a rest angle of about a 35 to 45 degree angle. At this point you should be able to gently assist the boom fully up or down by hand.

TIP - If you have shortened the boom, balancing may involve adding some weight to the end of the boom to compensate. Example – You have shortened the supplied boom by one metre. That metre of boom might weigh one kilogram. To compensate you can insert an appropriate SHS or round tube that has a similar weight and fix it inside the end of your shortened boom. Note it must be fixed inside the end of the boom. Because you have shortened your boom you may need a little more than the one kilogram you removed. Trial and error until you achieve balance.

4. Once balance is achieved you are ready to program your boom gate. Refer to your manual for programming instructions but essentially this will involve teaching the control board the end stops and required force to open and close. If you have not balanced correctly the board may compensate but you will be shortening the life of your boom gate motor and control board so make sure you do not do this step until you have nice balance.

TIP – After balancing the boom you need to insert small loops (45mm length of light gauge single strand cable with both ends stripped about 8mm) into each of the normally closed (NC) safety circuits. These will be removed later if you add safety accessories.

5. Once you have your boom gate running nicely you can then add your accessories one at a time testing each for correct operation before starting the next one.

- **TIP** – If you are using solar power it is a good idea to program first with an inverter generator before changing over to solar.
- **TIP** – It is recommended that all booms over three metres be supported by either drop down leg or boom support stand.
- **TIP** – Boom gates typically get installed in commercial and industrial sites that also typically have dirty and unstable power. Use a CM90 filter to protect your installation and improve reliability.

