

CL8542450  
10/2018 rev 2

# HYDRO

**HD.3524E - HD.3524E AC**  
**HD.5024E - HD.5024E AC**

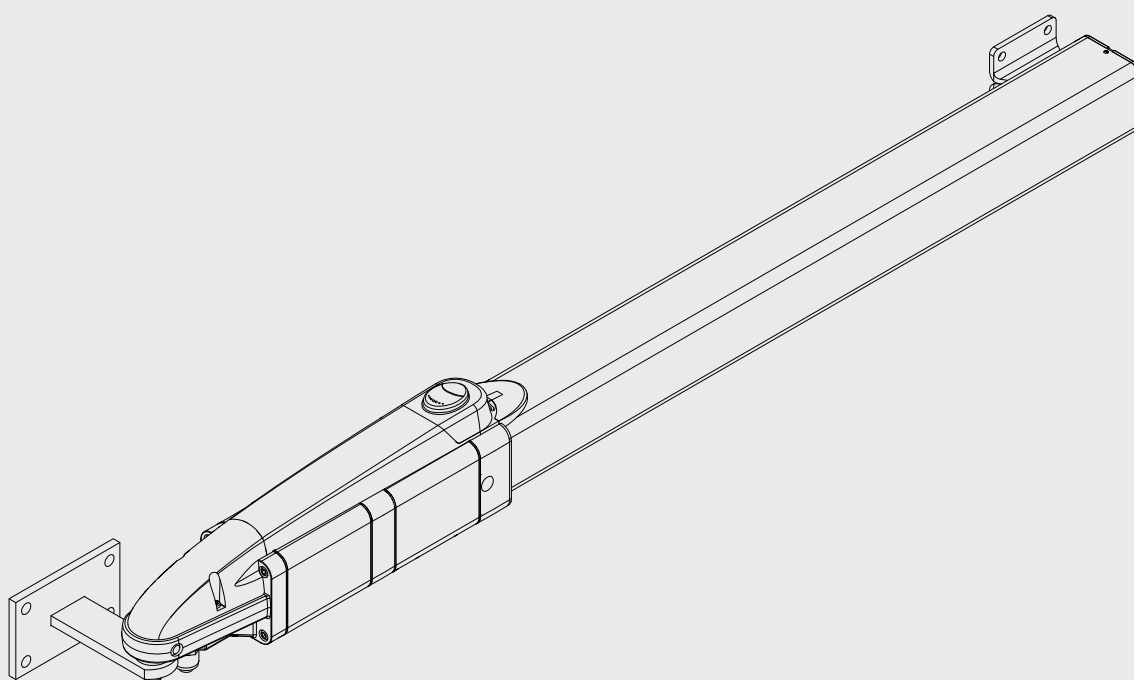

**CAB**

CE

IT

EN

DE

FR

ES

PL

1

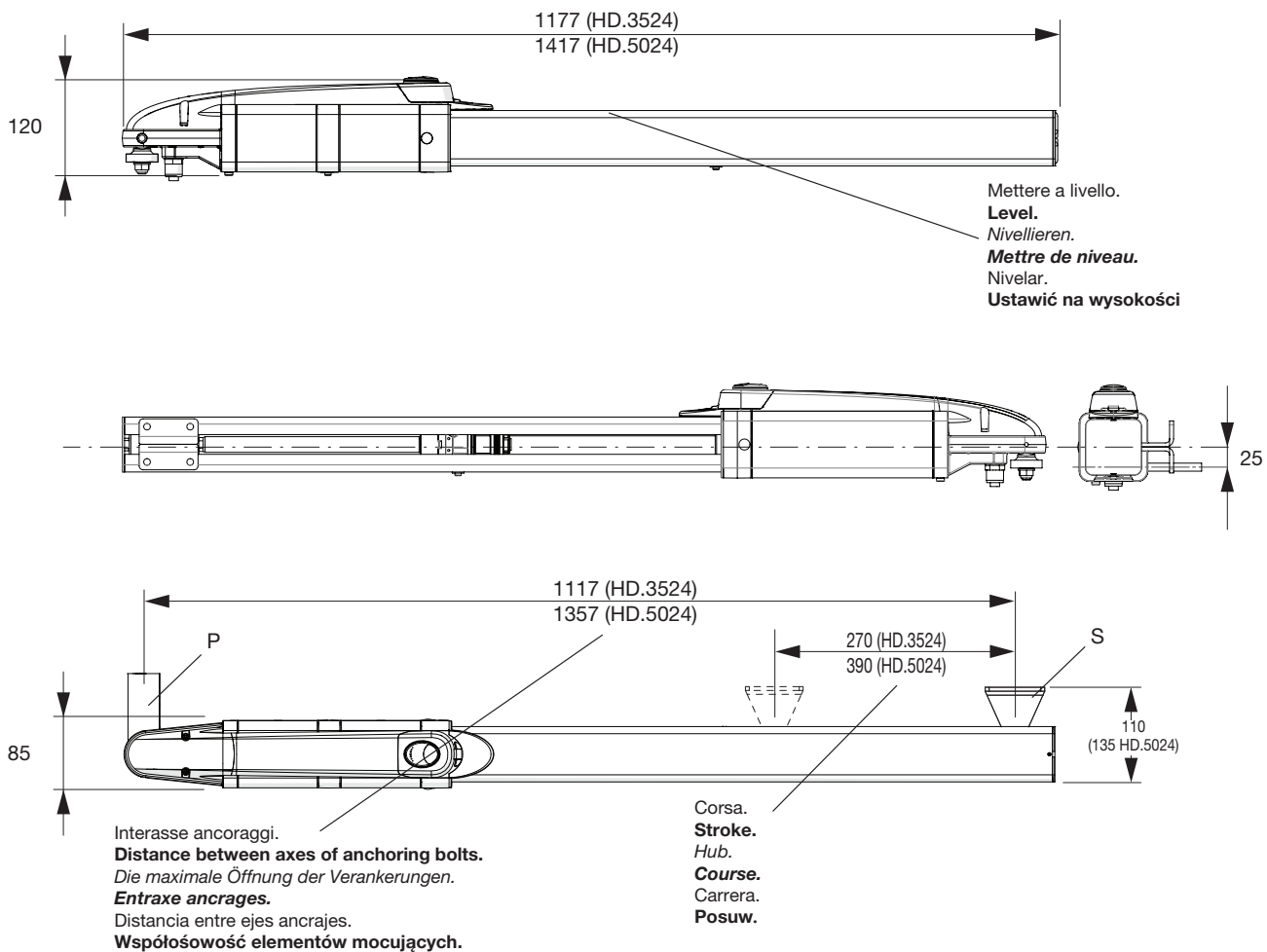

2

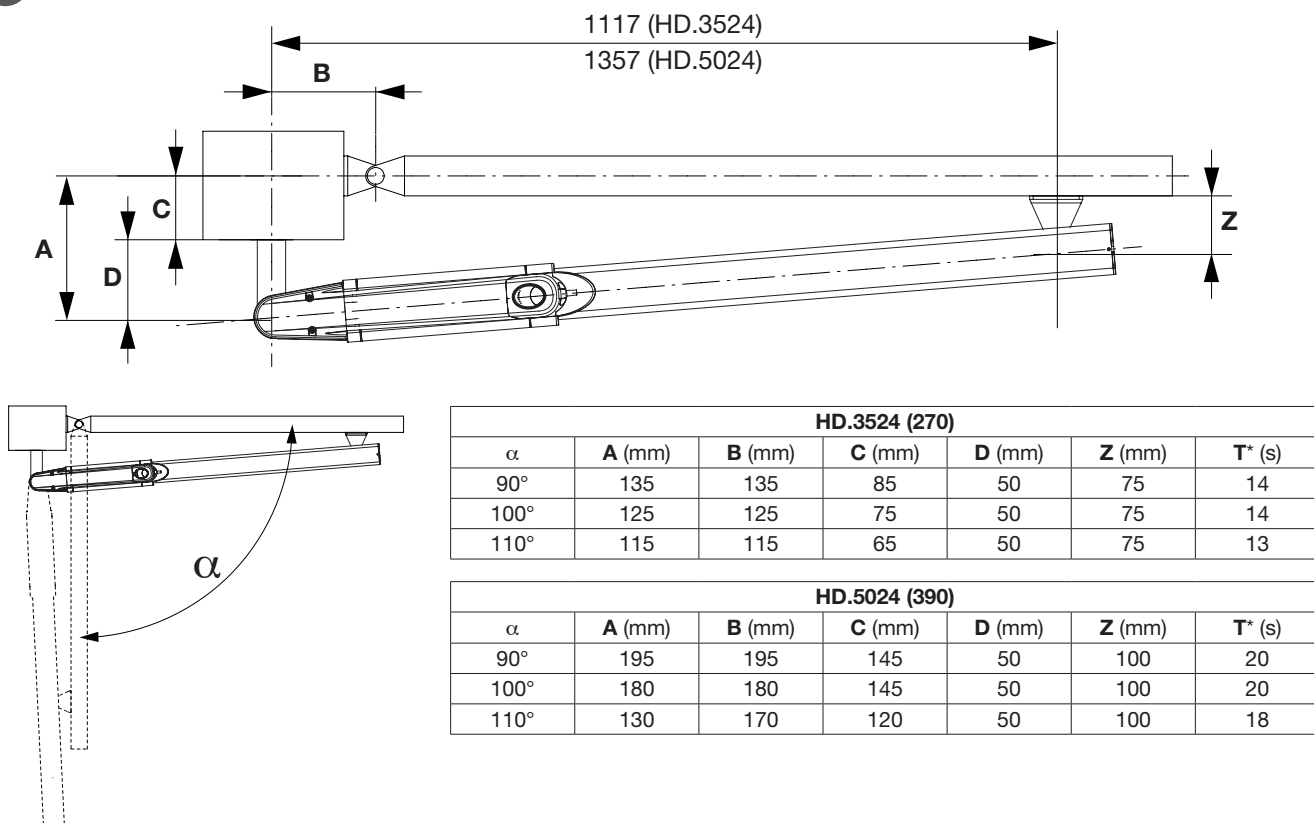

\*Tempo apertura indicativo, escluso rallentamento - \*Indicative opening time, excluded slowdown - \*Hinweisende öffnungszeiten, ausschließliches Verlangsamungen  
\*Temps indicatif d'ouverture, ralentissement exclu - \*Tiempo indicativo de abertura, deceleración excluido - \*Wskazujący czas otwierania, wyłączeń zwalniania

3

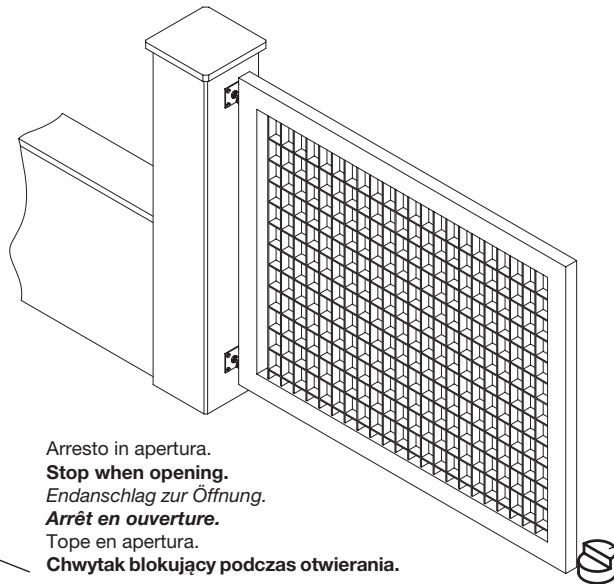

Arresto in apertura.  
**Stop when opening.**  
*Endanschlag zur Öffnung.*  
**Arrêt en ouverture.**  
 Tope en apertura.  
**Chwytek blokujący podczas otwierania.**

Arresto in chiusura.  
**Stop when closing.**  
*Endanschlag zur Schließung.*  
**Arrêt en fermeture.**  
 Tope de cierre.  
**Chwytek blokujący podczas zamykania.**

4

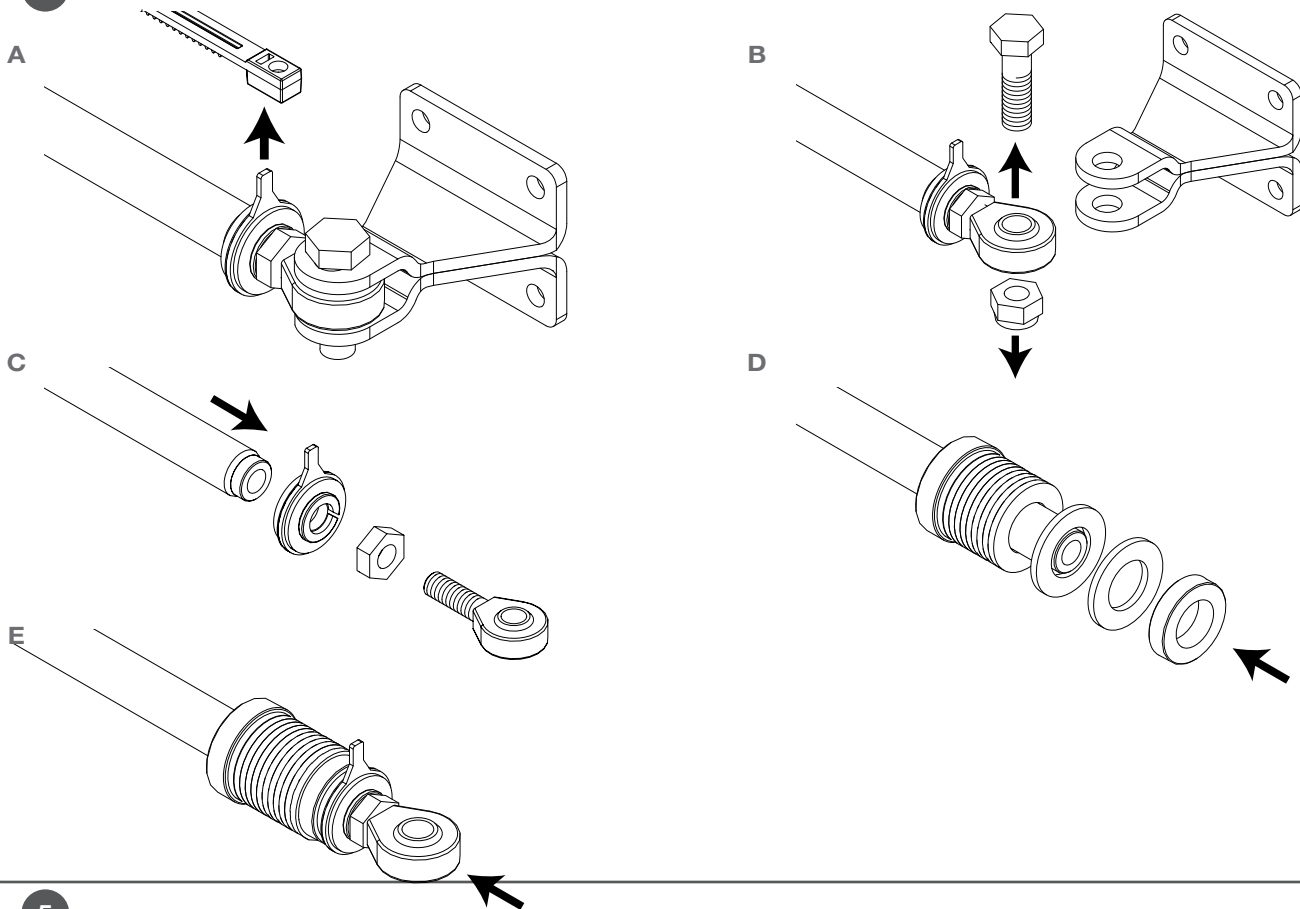

5

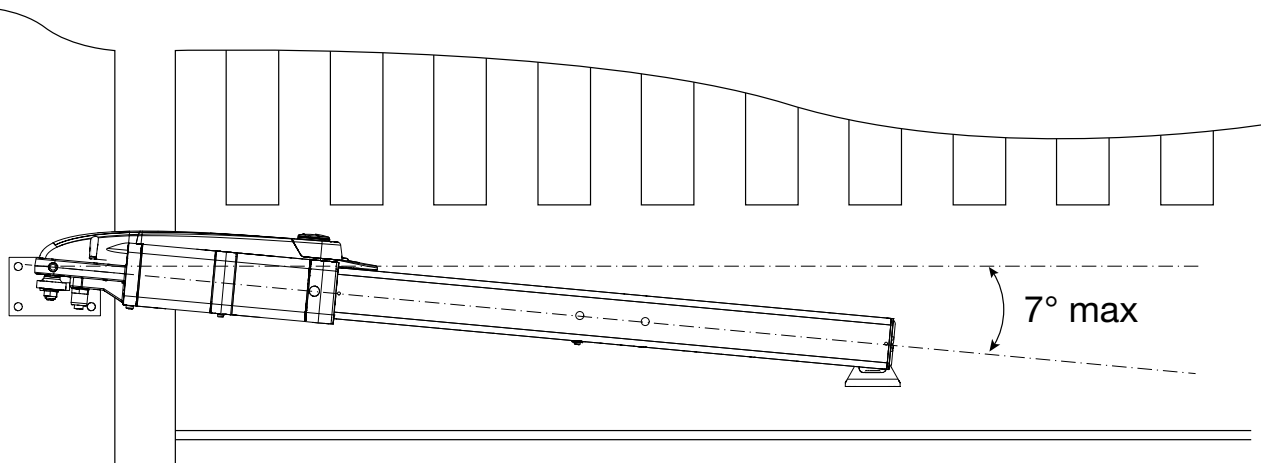

6

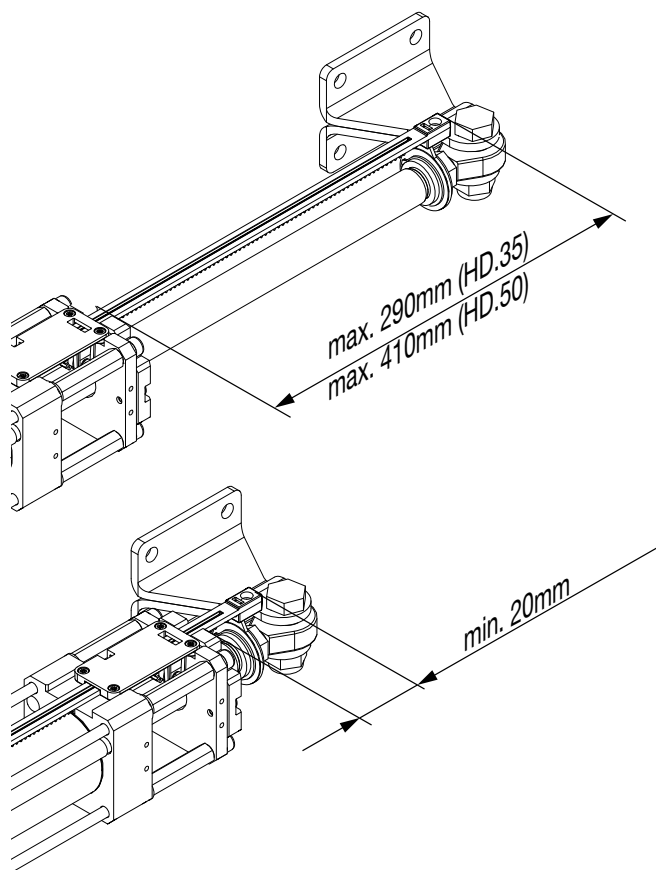

7

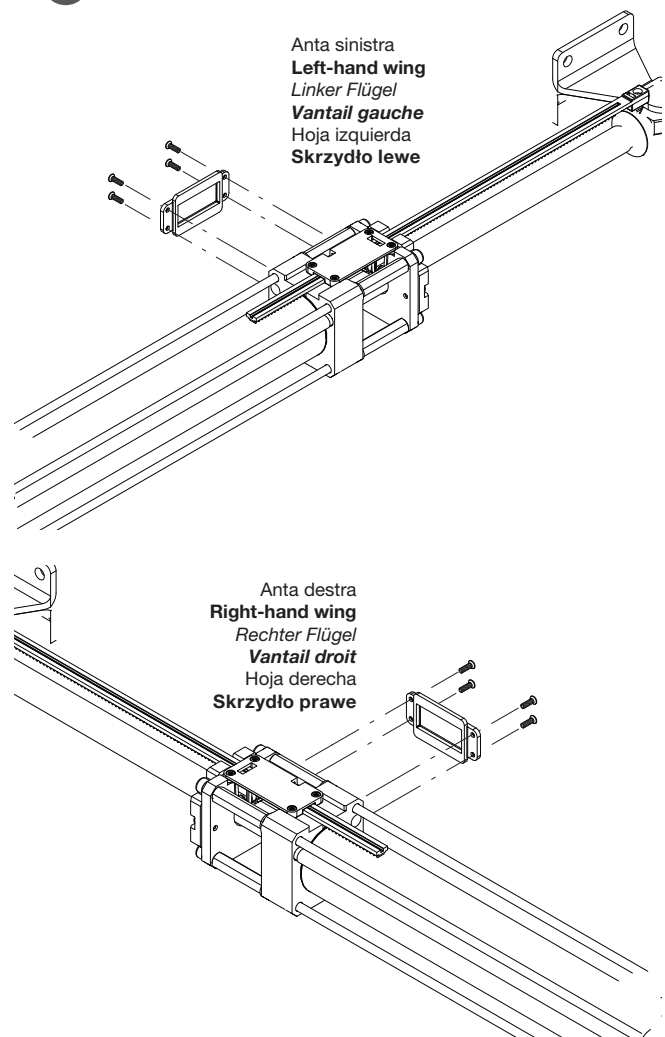

8

Tagliare a misura e saldare  
**Cut to size and weld**  
Auf Maß zuschneiden und schweißen  
**Couper à la bonne mesure et souder**  
Cortar a medida y soldar  
**Wyciąć według rozmiaru i zespawać**

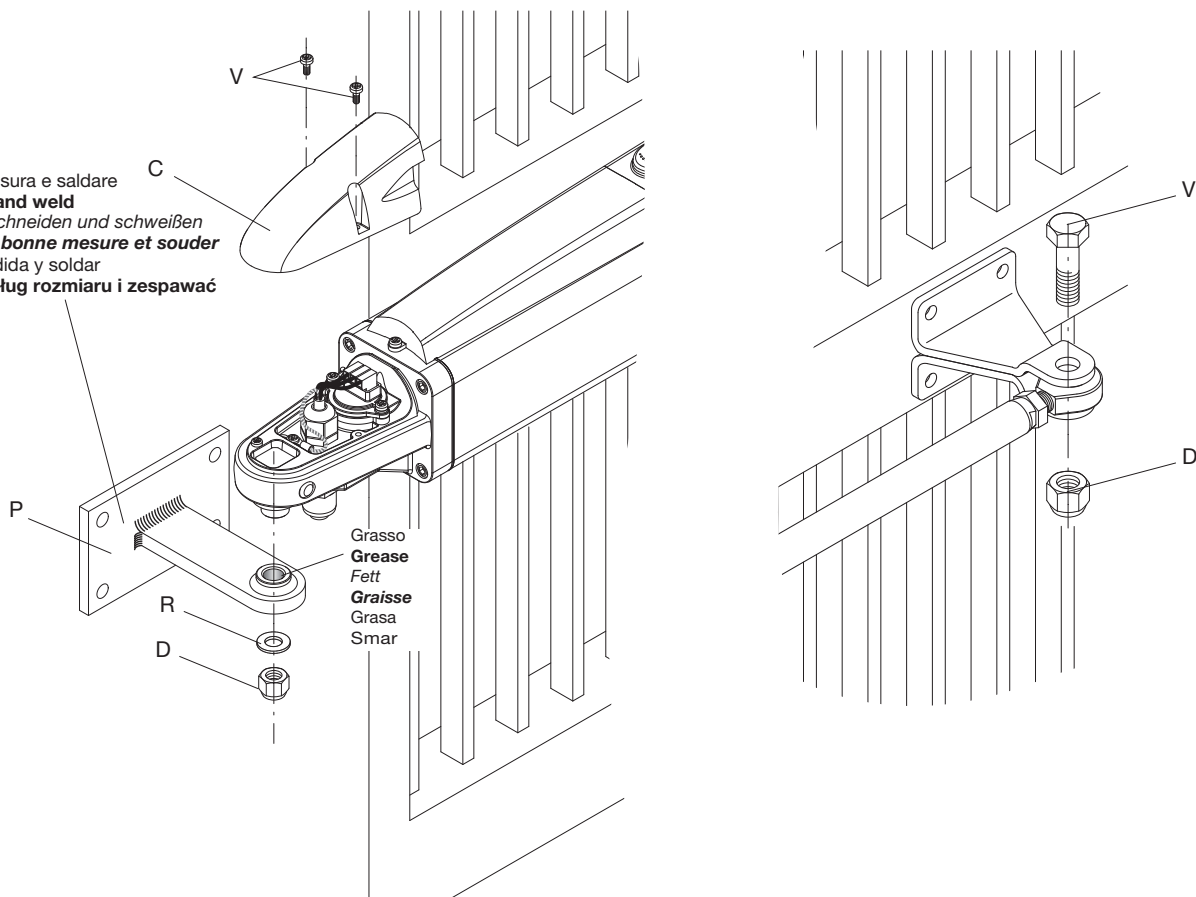

9

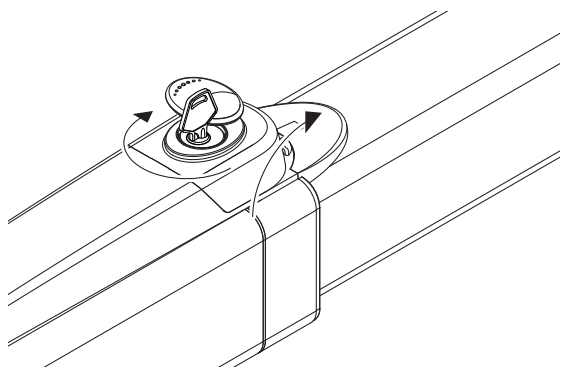

10

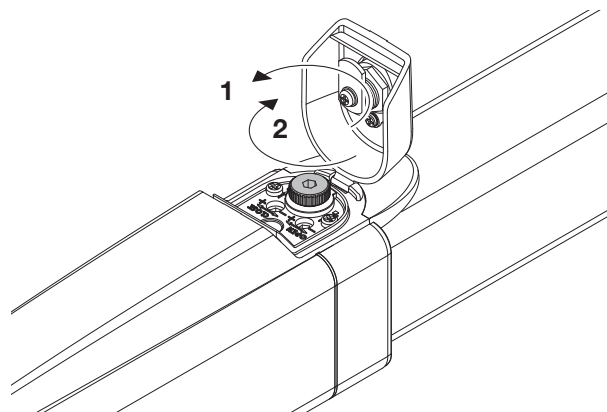

11

Anta sinistra  
**Left-hand wing**  
 Linker Flügel  
**Vantail gauche**  
 Hoja izquierda  
**Skrzydło lewe**

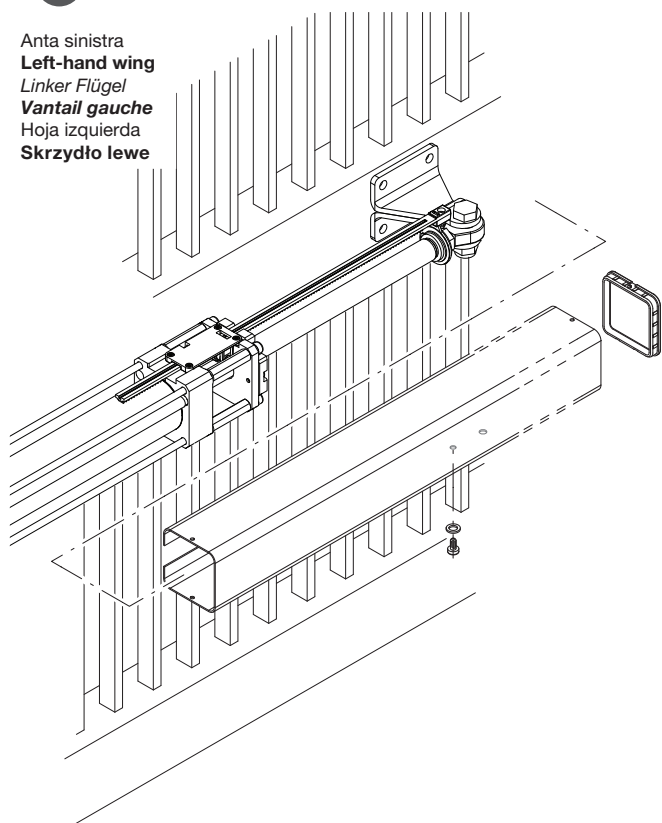

Anta destra  
**Right-hand wing**  
 Rechter Flügel  
**Vantail droit**  
 Hoja derecha  
**Skrzydło prawe**

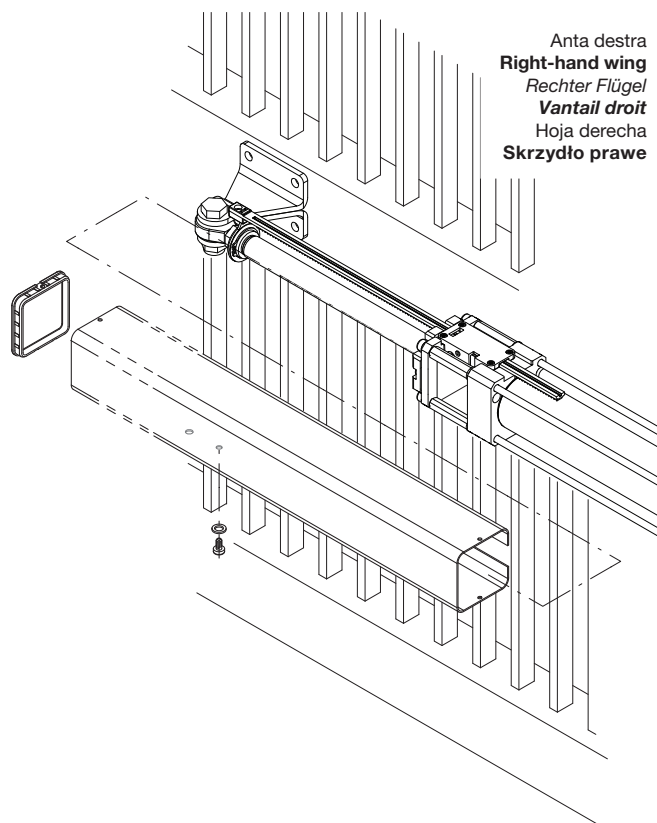

12

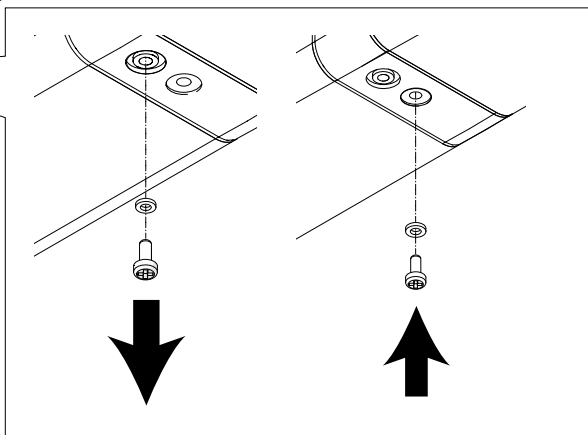
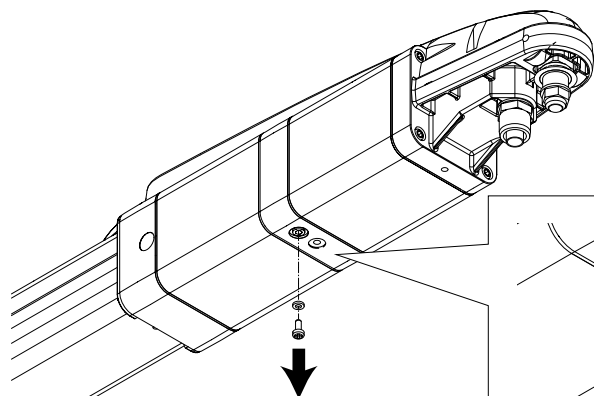

13

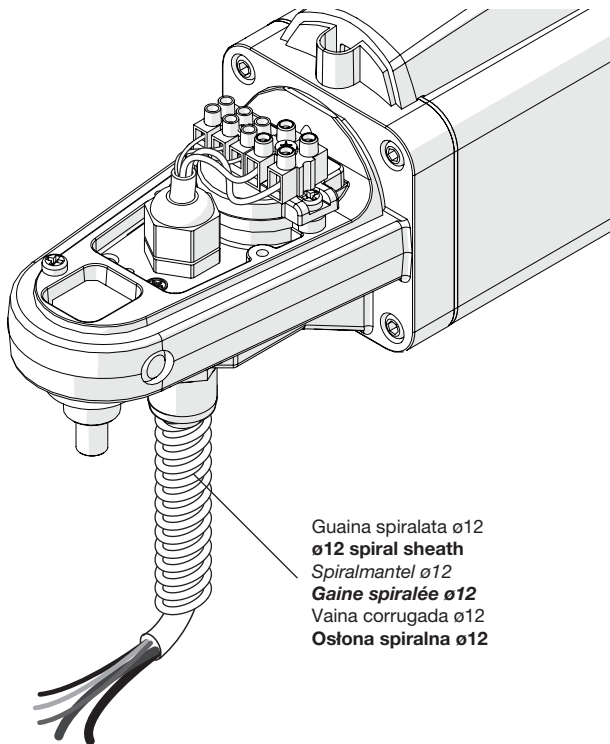

Guaina spiralata  $\varnothing 12$   
 **$\varnothing 12$  spiral sheath**  
 Spiralmantel  $\varnothing 12$   
**Gaine spiralée  $\varnothing 12$**   
 Vaina corrugada  $\varnothing 12$   
**Ostona spiralna  $\varnothing 12$**

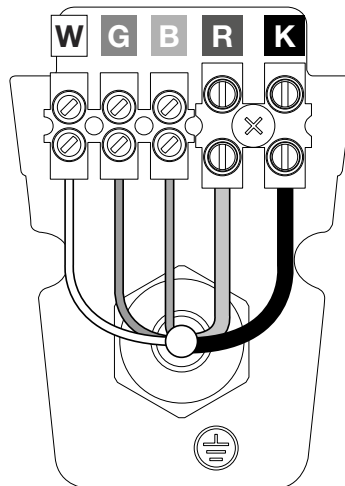

<b>ENC-</b>	<b>W</b>	Bianco <b>White</b> <i>Weiß</i> Blanc <b>Blanco</b> <i>Biały</i>
<b>ENC</b>	<b>G</b>	Verde <b>Green</b> <i>Grün</i> Vert <b>Verde</b> <i>Zielony</i>
<b>ENC+</b>	<b>B</b>	Marrone <b>Brown</b> <i>Braun</i> Brun <b>Marrón</b> <i>Brązowy</i>
<b>M+24</b>	<b>R</b>	Rosso <b>Red</b> <i>Rot</i> Rouge <b>Rojo</b> <i>Czerwony</i>
<b>M-24</b>	<b>K</b>	Nero <b>Black</b> <i>Schwarz</i> Noir <b>Negro</b> <i>Czarny</i>

14

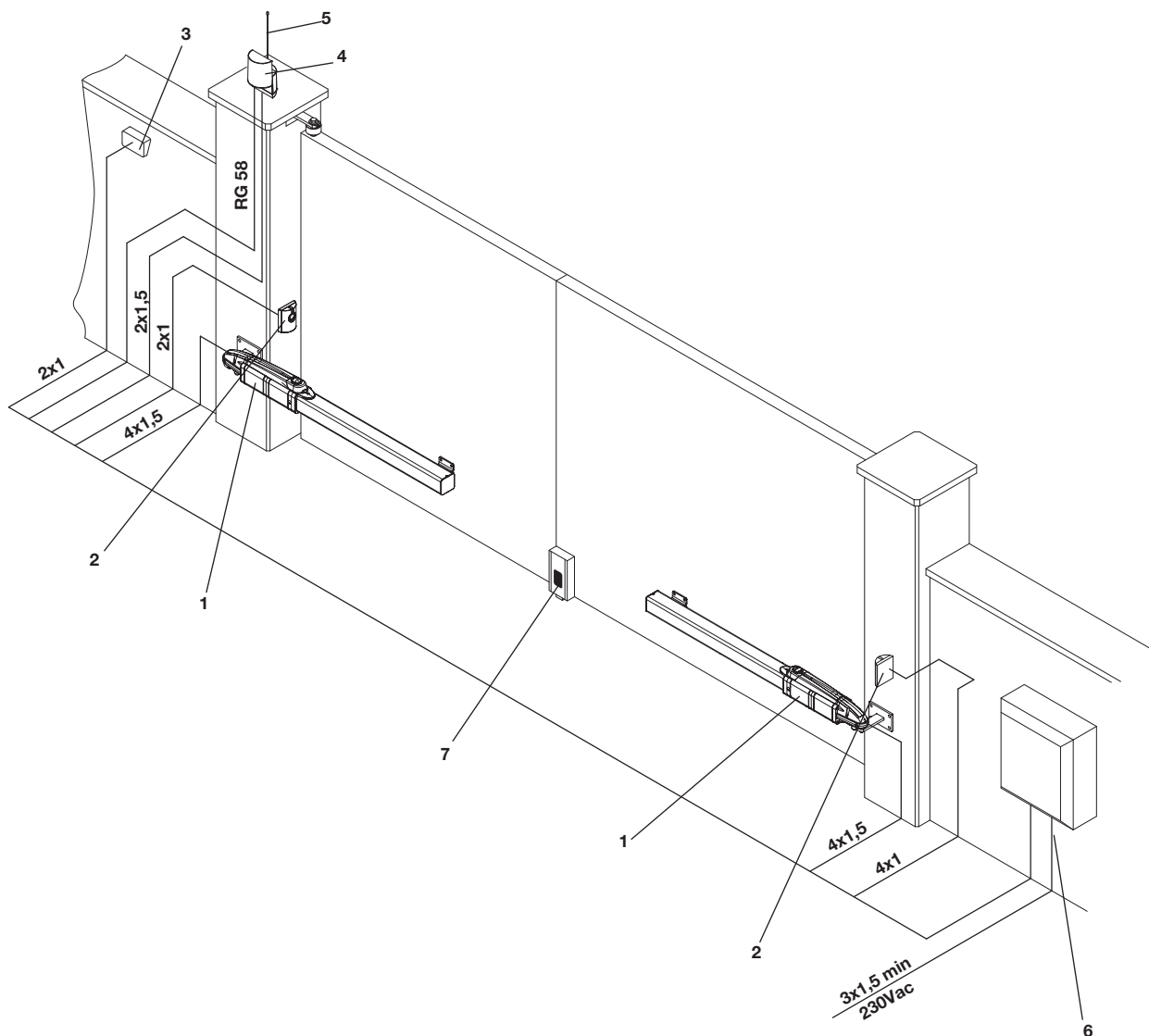

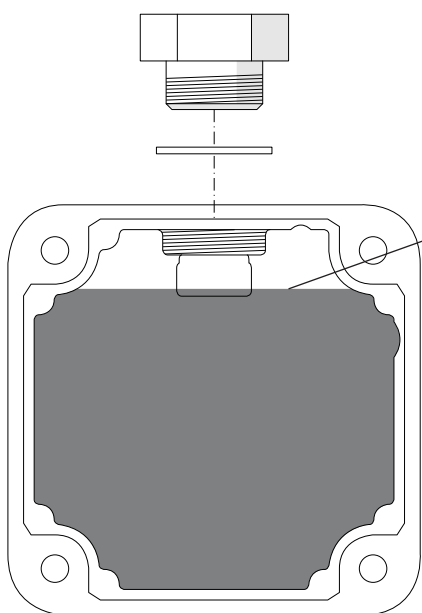
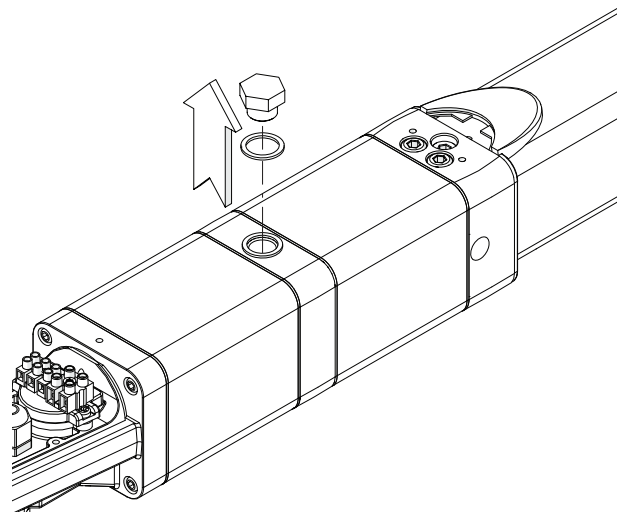
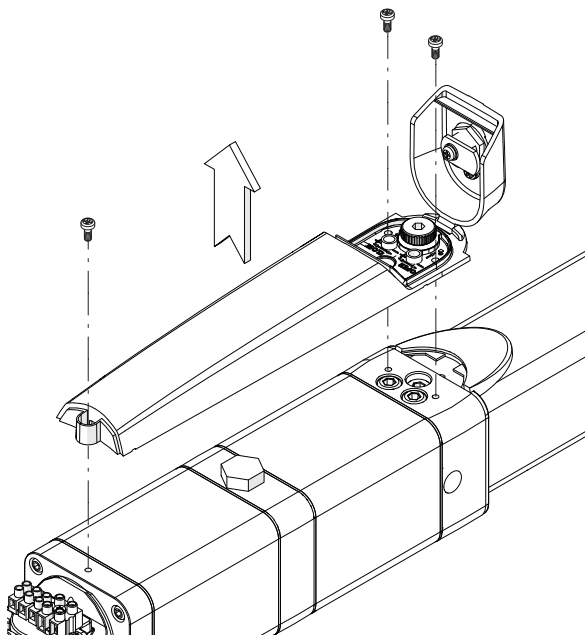
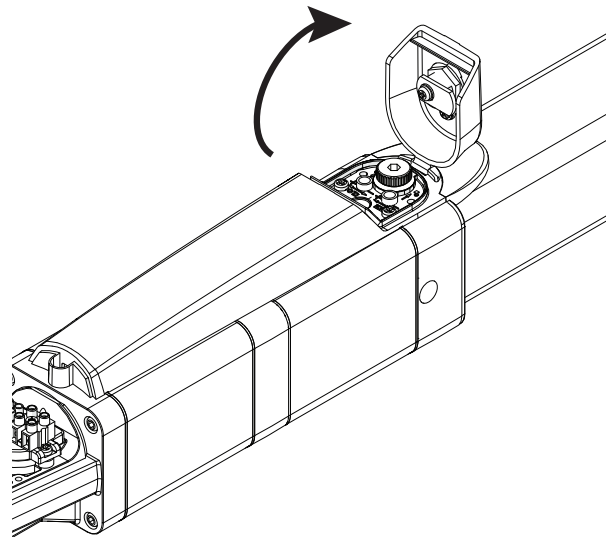
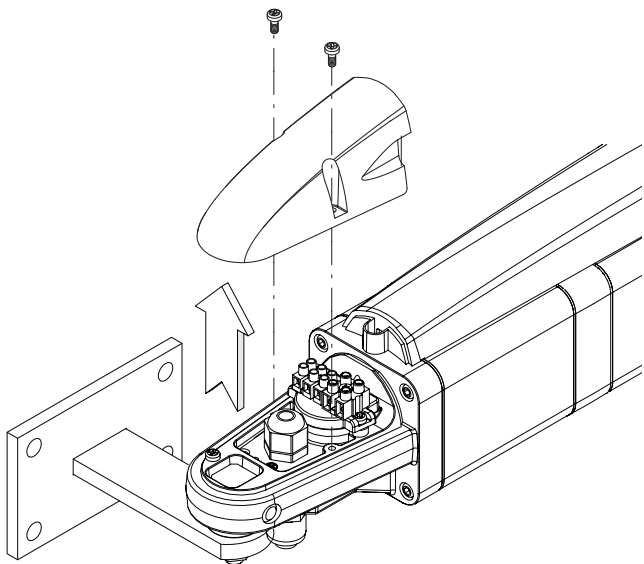

Livello olio  
 Oil level  
 Ölstand  
 Niveau d'huile  
 Nivel de aceite  
 Poziom oleju

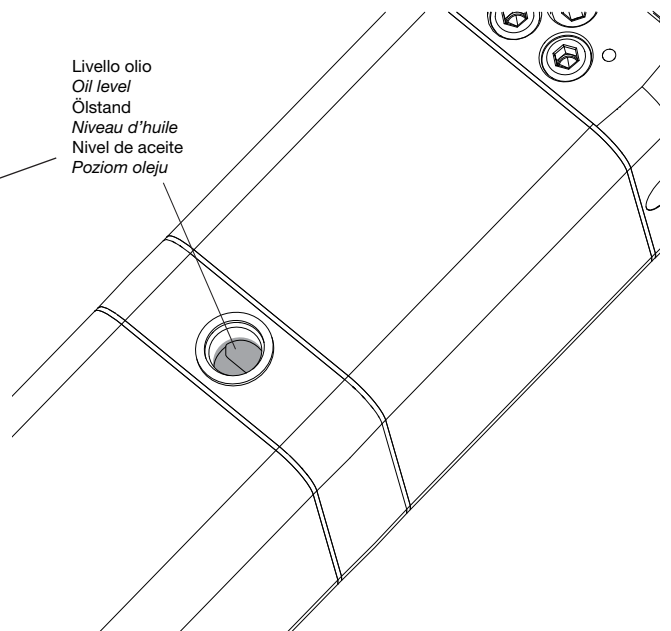

**GENERAL INFORMATIONS**

The product shall not be used for purposes or in ways other than those for which the product is intended for and as described in this manual.



Incorrect uses can damage the product and cause injuries and damages.

The company shall not be deemed responsible for the non-compliance with a good manufacture technique of gates as well as for any deformation, which might occur during use.

Keep this manual for further use.

**INSTALLER GUIDE**

This manual has been especially written to be use by qualified fitters.



Installation must be carried out by qualified personnel (professional installer, according to EN 12635), in compliance with Good Practice and current code.

Make sure that the structure of the gate is suitable for automation.

The installer must supply all information on the automatic, manual and emergency operation of the automatic system and supply the end user with instructions for use.

**GENERAL WARNINGS**

Packaging must be kept out of reach of children, as it can be hazardous.

For disposal, packaging must be divided the various types of waste (e.g. carton board, polystyrene) in compliance with regulations in force.

Do not allow children to play with the fixed control devices of the product.

Keep the remote controls out of reach of children.



This product is not to be used by persons (including children) with reduced physical, sensory or mental capacity, or who are unfamiliar with such equipment, unless under the supervision of or following training by persons responsible for their safety. Apply all safety devices (photocells, safety edges, etc.) required to keep the area free of impact, crushing, dragging and shearing hazard.

Bear in mind the standards and directives in force, Good Practice criteria, intended use, the installation environment, the operating logic of the system and forces generated by the automated system.

Installation must be carried out using safety devices and controls that meet standards EN 12978 and EN 12453.

Only use original accessories and spare parts, use of non-original spare parts will cause the warranty planned to cover the products to become null and void.

All the mechanical and electrical parts composing automation must meet the requirements of the standards in force and outlined by CE marking.

**ELECTRICAL SAFETY**

An omnipolar switch/section switch with remote contact opening equal to, or higher than 3mm must be provided on the power supply mains.

Make sure that before wiring an adequate differential switch and an overcurrent protection is provided.

Pursuant to safety regulations in force, some types of installation require that the gate connection be earthed.

During installation, maintenance and repair, cut off power supply before accessing to live parts.



Also disconnect buffer batteries, if any are connected.

The electrical installation and the operating logic must comply with the regulations in force.

The leads fed with different voltages must be physically separate, or they must be suitably insulated with additional insulation of at least 1 mm.

The leads must be secured with an additional fixture near the terminals.

During installation, maintenance and repair, interrupt the power supply before opening the lid to access the electrical parts

Check all the connections again before switching on the power.

The unused N.C. inputs must be bridged.

**WASTE DISPOSAL**

As indicated by the symbol shown, it is forbidden to dispose this product as normal urban waste as some parts might be harmful for environment and human health, if they are disposed of incorrectly.

Therefore, the device should be disposed in special collection platforms or given back to the reseller if a new and similar device is purchased.

An incorrect disposal of the device will result in fines applied to the user, as provided for by regulations in force.

*Descriptions and figures in this manual are not binding.*

*While leaving the essential characteristics of the product unchanged, the manufacturer reserves the right to modify the same under the technical, design or commercial point of view without necessarily update this manual.*



## IMPORTANT

- Before installing the operator read these instructions.
- Use of a **HYDRO** product for any application not described in this instruction manual is prohibited.
- The user must be instructed on the use of the automation system.
- The user must be consigned the instruction manual.
- All CAB products are insured against damage or injury caused by manufacturing defects under the essential condition that the operator has the CE marking and all genuine CAB components are installed.

## 1) GENERAL INFORMATION

Hydraulic operator for swing gates, available in various versions:

MODEL	Door leaf weight (kg)	Door leaf width (m)	Stroke length (mm)	Type of lock
HD.3524E	500	3,5	270	■
HD.3524E AC	500	3,5	270	◁▷
HD.5024E	500	5	390	■
HD.5024E AC	500	5	390	◁▷

LEGENDA	DESCRIZIONE
■	Reversible (Requires electric lock)
◁▷	One-way

“HD.3524E AC” and “HD.5024E AC” models are equipped with hydraulic lock on the opening stroke and do not require an electric lock\* since the operator locks the wing shut when the motor is not in running.

Models without hydraulic lock on opening stroke (HD.3524E - HD.5024E) always require an electric lock to guarantee the wing is locked shut mechanically. All models are equipped with adjustable hydraulic slowdown on the closing stroke.

\*For wings longer than 2m an electric lock is recommended even on one-way models.

All models are equipped with Encoder function used both for slowdown phase management and as an anti-crushing sensor. For the correct use of these functions, it is essential to use the HYBRA 24 central control unit, refer to the instructions supplied with the central unit for further information.

## 2) TECHNICAL DATA

MODEL	HD.3524E	HD.3524E AC	HD.5024E	HD.5024E AC
Power supply	24 Vdc			
Motor	240 W			
Absorbed current	5 A			
Protection rating	IP55			
Oil	BIO OIL			
Operating temp.	-20°C/+50°C			
Hydraulic lock	Reversible	Opening and closing	Reversible	Opening and closing
Thrust	4000 N			
Pump delivery	1.4l/min 2800rpm			
Rod speed	2 cm/s			
Working stroke	270mm		390mm	
Stroke time	14s		20s	
N° cons.ve manoeuv.	Intensive use			
Braking	Electronic			
Max gate	3.5m electric lock	3.5m (from 2 to 3.5m electric lock)	5m electric lock	5m (from 2 to 3.5m electric lock)

## 3) PRELIMINARY CHECKS

For the gate automation to work properly, the actual gate must have the following characteristics:

- it must be robust and rigid.
- the hinges must have only limited play and provide smooth and gentle gate movements.
- the whole height of the wings must be in contact when closed.

## 4) OVERALL DIMENSIONS (FIG.1)

Fig. 1 shows the main overall dimensions for the various models, values are expressed in mm.

## 5) INSTALLATION MEASURES

Fig. 2 shows the main installation values and the approximate opening times.

## 6) GATE STOPS

If they are not already provided, install gate stops on the opening and closing stroke limits (Fig.3) regardless of the type of operator being installed. The closed stop in particular is indispensable given the special characteristics of hydraulic operators. See “maintain stop” function in the instructions for the control unit.

If there is no possibility of installing a stop in the opening, it is essential to apply the supplied mechanical lock rings to the stem (fig.4).

The number of rings to be applied depends on the installation values and the desired stop point, however, the X and Y terminals should be applied as shown in Figure 4-D.

## 7) INSTALLING THE AUTOMATION SYSTEM

- 1 **Remove the vent screw VS with its RS gasket. (see fig.12 and note "Vent screw")**
- 2 Before fixing the gear motor, the protection cover encoder circuit P (Figure 7) must be attached. The cover must be positioned on the side of the motor facing the gate, therefore the position is different if the gear motor is to be placed on the left or right door.
- 3 Establish the height of the automation from the ground (preferably as close to the centre of the wing as possible and along a solid cross rail). Remember that under the operator there is a vent hole (fig.12) and in certain conditions (e.g. rain or snow) it may draw liquid into the automation. For this reason it is best not to install the operator too close to the ground.
- 4 Weld or otherwise anchor plate P in place, see installation distances (Fig.2) and the installation diagram (Fig.8):
  - remove screws V and cover C
  - insert pin P in bracket P as in the figure
  - lock everything in place by washer R and self-locking nut D

Observe the distances given in the tables at fig. 2, correcting the length of the plate if necessary. In some cases a recess may have to be made in the post.

**It is essential that the installation distances are respected for the operator to work correctly.**

With reference to the installation tables note that:

For the wing to open 90°: A+B must be equal to the operator stroke

For the wing to open more than 90°: A+B must be less than the operator stroke.

Keep the length differences within 40mm. Over this difference the wing movement becomes uneven. When reducing lengths A and B, increase the wing speed.

Comply with all statutory regulations.

- 5 Release the operator (see section "manual gate operation")
  - Normally the gear motor is supplied already unlocked.
- 6 Slide out the ram shaft completely and then slide back in by approx. 10 mm. Lock the operator in place (fig.4).
  - Always leave a safety overrun of 10 mm in both the closing and opening strokes. The stroke length given in the technical data and installation tables has already been reduced by the necessary 20 mm.
  - Before proceeding with the fixing of the actuator on the door check that the values measured on the Encoder rack, as shown in Fig. 6 are respected.
- 7 Make sure the operator is kept perfectly level and mark the point where the bracket will be attached to on the wing.
  - Temporarily weld or bolt the bracket in place as shown in Fig.8.
  - A horizontal position of the actuator is always preferable, but if necessary, the joints on the brackets allow for good operation even if tilted slightly, as shown in Fig.5.
- 8 Release the operator and swing the gate by hand to check it moves freely to fully open and stops on the gate stop. The wing must move smoothly and evenly.
- 9 Anchor the bracket permanently.

NOTE: Vent plug (fig.12).

Next to the vent a dead hole has been provided where the plug and gasket can be kept for future use. On removing the plug and during the first operator manoeuvres a small quantity of oil may leak out. This is perfectly normal and should not be considered a fault.

## 8) MANUAL AND EMERGENCY GATE OPERATION (FIG.9-10)

If there is a power failure or malfunction the wings can be moved by hand as follows:

**Models with hydraulic lock (i.e. HD.35 C -HD.35 AC - HD.50 AC):**

- Use the special key supplied with the operator to open the protective cover of the release mechanisms (Fig.9).
- Turn the knob anticlockwise to disengage the automation. (Fig.10)
- The wing can now be opened and closed manually.
- To engage the automation turn the knob anticlockwise.
- Lock the cover shut.

**Models without hydraulic lock (i.e. HD.35 - HD.45 - HD.50):**

Since these models are reversible, simply open the electric lock and the wing can be moved manually.

Slowly push the wing by its outer end, accompanying it all the way to the gate stop. The movement may be made easier by slackening the release knob.

## 9) ADJUSTING THE THRUST

The actuator push force adjustment is performed electronically from the central control unit.

**CAUTION! This adjustment is directly linked to the safety level of the automation.**

**Make sure that the thrust applied on the wing complies with statutory regulations.**

## 10) THE PROTECTIVE COVERS (FIG.11)

Take great care in ensuring that the drain hole faces the ground.

## 11) WIRING (FIG.13)

The operator is supplied with the wiring cable already installed and wired (Fig.13). To connect it to the control unit see the diagram and instructions for the control unit. The power cable is best protected by a 12mm spiral sheath that has to be inserted in the coupling provided.

## 12) TOPPING UP/CHANGING OIL (FIG.15)

The oil level in all hydraulic operators must be periodically checked.

For normal use, it is recommended to replace the oil every 5 years, for particularly intensive use, replacement is preferable every 2/3 years.

For refilling, after disconnecting the system power supply, simply remove the two V screws securing the terminal block, remove the three H screws securing the C plastic cover and remove the T cap. The level should not exceed the quantity shown in Fig.15.

CAUTION!: Always shut-off the mains power before working on the gate

Only use BIO OIL.

## 13) WIRE DIAGRAM (FIG.14)

**Legend:**

- 1 Hydro 24V geared motor
- 2 Photocells
- 3 Key selector or digital keyboard
- 4 Beacon
- 5 Antenna
- 6 Control unit.
- 7 Electric lock

N.B.: The power cables must be kept separated from the auxiliary cables.

**IMPORTANT:** Installation of an electric lock is essential on models without hydraulic lock or if the wing is over 2 m long

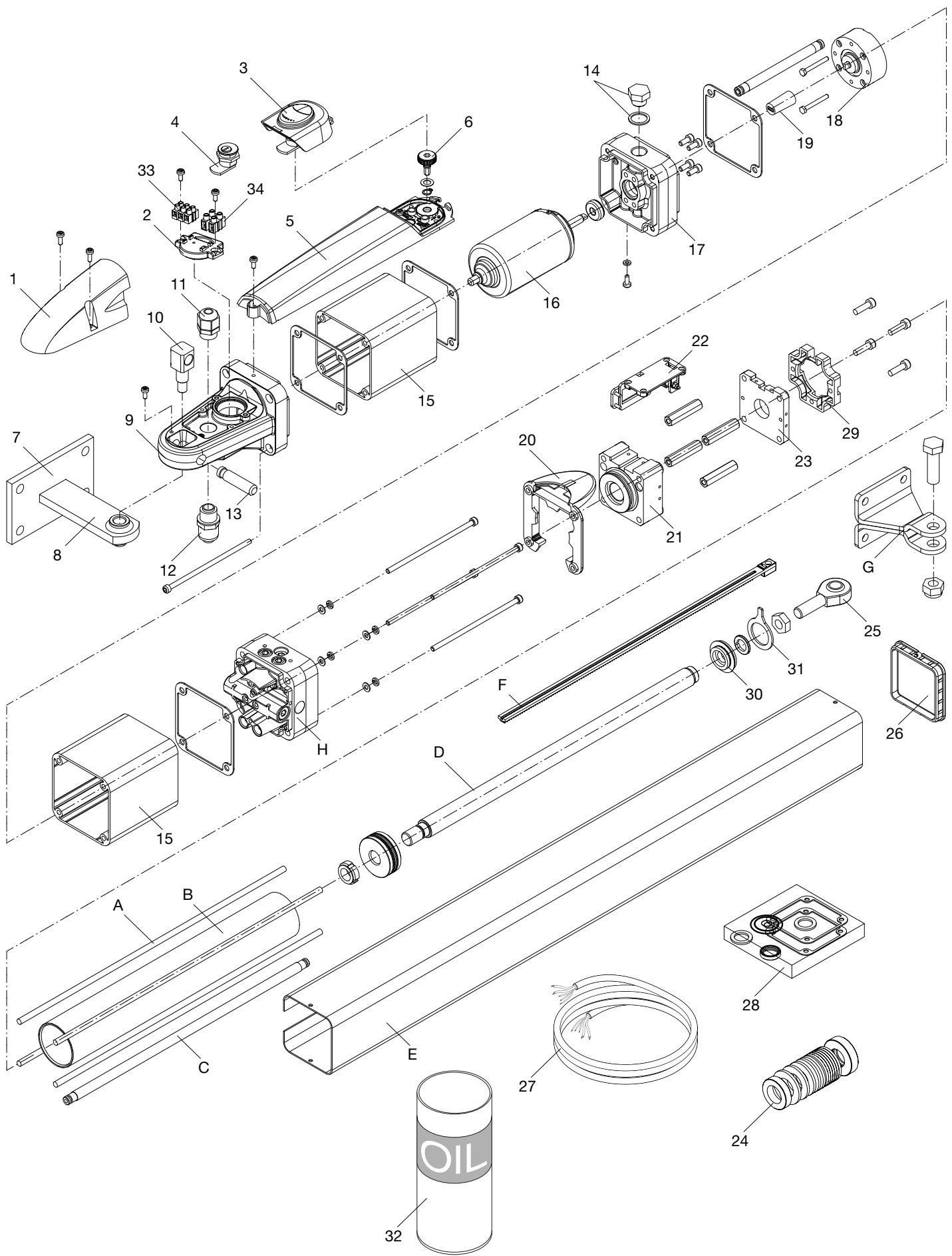

## HYDRO

N°	Denominazione - Description - Bezeichnung - Dénomination - Denominación - Określenie						Cod.
1	Carter morsettiera	Terminal housing	Gehäuse	Carter bornier	Cárter terminal	Karter	CF8144101
2	Connettore	Connector	Verbinder	Connecteur	Conector	Łącznik	CF8830092
3	Carter Mobile + Serratura	Cover + Lock	Bew. Gehäuse + Schloss	Carter mobile + Serrure	Cárter móvil + Cerradura	Karter Ruchomy + Zamek	C3747000
4	Serratura	Lock	Schloss	Serrure	Cerradura	Zamek	CF8765090
5	Carter Fisso	Housing	Festes Gehäuse	Carter fixe	Cárter fijo	Karter Stały	CF8144100
6	Manopola Sblocco	Release knob	Entrieg.knauf	Poignée déblocage	Pomo desbloqueo	Pokrętko odbl.	CF8621021
7	Piastra muro	Wall plate	Wandplatte	Platine mur	Placa de muro	Płyta ścienna	9623060
8	Staffa posteriore	Wall bracket	Hinterer Bügel	Patte arrière	Estribo poster.	Zaczep tylny	CF8819031
9	Fondello	End plate	Bodenscheibe	Fond	Fondo	Spód	C3395020
10	Snodo	Pivot	Gelenk	Articulation	Articulación	Przegub	CF8780200
11	PG11	PG11	PG11	PG11	PG11	PG11	CF8646011
12	RPG112	RPG112	RPG112	RPG112	RPG112	RPG112	CF8516012
13	Perno snodo	Pivot lock pin	Gelenkbolzen	Pivot articul.	Perno articul.	Sworzeń przegubu	CF8621022
14	Tappo olio	Oil cap	Ölstopfen	Bouchon huile	Tapón de aceite	Korek wlewu oleju	CF8837055
15	Serbatoio	Tank	Tank	Réservoir	Depósito	Zbiornik	C5667013
16	Motore	Motor	Motor	Moteur	Motor	Silnik	CF8587100
17	Flangia motore	Motor flange	Motorflansch	Bride moteur	Brida del motor	Kołnierz silnika	C5396212
18	Pompa	Pump	Pumpe	Pompe	Bomba	Pompa	CF8634005
19	Giunto	Joint	Verbindung	Joint	Junta	Złącze	CF8424002
20	Flangia anteriore	Flange	Vord. Flansch	Bride avant	Brida anterior	Kołnierz przedni	C5396004
21	Testa Encoder	Slowdown head	Kopf Verlangs.	Tête ralentiss.	Cabeza decel.	Przód zwalniania	C4396202
22	Encoder	Encoder	Encoder	Encoder	Encoder	Encoder	C4362002
23	Piastra Encoder	Encoder plate	Encoder platte	Platine Encoder	Placa de Encoder	Płyta Encoder	CF8623250
24	Blister HD24 A20	Blister HD24 A20	Blister HD24 A20	Blister HD24 A20	Blister HD24 A20	Blister HD24 A20	C4089351
25	Testa snodo	Pivot head	Gelenkkopf	Tête articul.	Cabeza articul.	Przód przegubu	CF8780010
26	Tappo	End cap	Deckel	Bouchon	Tapón	Zatyczka	CF8837150
27	Cavo alimentaz.	Power cable	Stromkabel.	Câble alim.	Cable alimen.	Przewód zasilania	CF8171161
28	KIT guarnizioni	SET Gaskets	Dichtungen KIT	KIT Garniture	Juntas KIT	SET Uszczelka	9688077
29	Flangia Posteriore	Head flange	Hint. Flansch	Bride arrière	Brida post	Kołnierz Tylny	CF8396200
30	Rondella flangiata	Flange washer	Geflanschte Unterlegscheibe	Rondelle bridée	Arandela bridada	Podkładka kołnierzowa	CF8345033
31	Leva trascinamento	Drag lever	Antriebshebel	Levier entrainement	Palanca de arrastre	Dźwignia przesuwania	CF8540050
32	Tanica olio	Oil tank	Ölbehälter	Réservoir huile	Bidón de aceite	Zbiornik oleju	9603002
33	Morsettiera 3 poli	3 poles Terminal board	3-polige Klemmenbrett	Bornier 3 pôles	Terminal de 3 polos	Listwa zaciskowa 3-biegunowa	CF8585011
34	Morsettiera 2 poli	2 poles Terminal board	2-polige Klemmenbrett	Bornier 2 pôles	Terminal de 2 polos	Listwa zaciskowa 2-biegunowa	CF8585012

A	Barra M6 per HD.35/HD.35 C/HD.35 AC/HD.45 - M6 rod- Stange M6- Barre M6- Barra M6- Drażek M6	CF8954012
	Barra M6 per HD.50/HD.50 AC - M6 rod- Stange M6 - Barre M6- Barra M6- Drażek M6	CF8954013
B	Tubo per HD.35/HD.35 C/HD.35 AC/HD.45 - Barrel - Rohrleitung - Tube - Tubo - Rura	C5868003
	Tubo per HD.50/HD.50 AC - Barrel - Rohrleitung - Tube - Tubo - Rura	C5868005
C	Canna per HD.35/HD.35 C/HD.35 AC/HD.45 - Rod housing- Rohr - Canne- Conducto - Tuleja	CF8868002
	Canna per HD.50/HD.50 AC - Rod housing- Rohr - Canne- Conducto - Tuleja	CF8868003
D	Stelo per HD.3524 - Ram shaft - Schaft - Tige piston- Vástago - Trzpień	CF8829008
	Stelo per HD.5024 - Ram shaft - Schaft - Tige piston- Vástago - Trzpień	CF8829007
E	Copristelo per HD.35/HD.35 C/HD.35 AC/HD.45 - Ram sleeve - Schaftdeckel - Carter piston - Cubrevástago- Oslona trzpienia	C5868000
	Copristelo per HD.50/HD.50 AC - Ram sleeve - Schaftdeckel - Carter piston - Cubrevástago- Oslona trzpienia	C5868001
F	Crema gliera HD.3524 EAC/HD.3524 E - Rack - Rack - Grille - Rack - Stojak	C5272005
	Crema gliera HD.5024 EAC/HD.5024 E - Rack - Rack - Grille - Rack - Stojak	CF8272005
G	Staffa Anteriore per HD.35/HD.35 C/HD.35 AC/HD.45 - Gate bracket - Vord. Bügel - Bride avant - Estribo anterior - Zaczep Przedni	CF8819030
	Staffa Anteriore per HD.50/HD.50 AC - Gate bracket - Vord. Bügel - Bride avant - Estribo anterior - Zaczep Przedni	CF8819033
H	Distributore 3524 AC / 5024 AC - Distributor - Verteiler - Distributeur - Distribuidor - Dystrybutor	C4396232
	Distributore 3524 / 5024 - Distributor - Verteiler - Distributeur - Distribuidor - Dystrybutor	C4396233

### NORME DI SICUREZZA

- Non sostare nella zona di movimento delle ante.
- Non lasciare che i bambini giochino con i comandi o in prossimità delle ante.
- In caso di anomalie di funzionamento non tentare di riparare il guasto ma avvertire un tecnico specializzato.

### MANOVRA MANUALE E D'EMERGENZA

In caso di mancanza dell'energia elettrica o di guasto, per azionare manualmente le ante procedere come segue:

#### Modelli dotati di blocco idraulico (HD.3524E AC - HD.5024E AC):

- Utilizzando la chiave personalizzata, fornita in dotazione con ogni attuatore, aprire lo sportellino di protezione del meccanismo di sblocco (Fig.1).
- Ruotare la manopola in senso antiorario per sbloccare l'automazione (Fig.2).
- È ora possibile aprire/chiedere manualmente l'anta.
- Per ripristinare il funzionamento automatico, ruotare la manopola in senso orario.
- Richiudere a chiave lo sportellino di protezione.

#### Modelli sprovvisti di blocco idraulico (HD.3524E - HD.5024E AC):

Questi modelli, essendo reversibili richiedono semplicemente lo sgancio dell'elettroserratura, dopodiché l'anta può essere manovrata manualmente.

Spingere con moderazione l'anta alla sua estremità, accompagnandola per tutta la corsa.

La manovra può essere agevolata allentando la manopola di sblocco.

### MANUTENZIONE

- Controllare periodicamente l'efficienza dello sblocco manuale di emergenza.
- Astenersi assolutamente dal tentativo di effettuare riparazioni, potreste incorrere in incidenti; per queste operazioni contattare un tecnico specializzato.
- Verificare periodicamente l'efficienza dei dispositivi di sicurezza e le altre parti dell'impianto che potrebbero creare pericoli in seguito ad usura.

### SMALTIMENTO

Qualora il prodotto venga posto fuori servizio, è necessario seguire le disposizioni legislative in vigore al momento per quanto riguarda lo smaltimento differenziato ed il riciclaggio dei vari componenti (metalli, plastiche, cavi elettrici, ecc.); è consigliabile contattare il vostro installatore o una ditta specializzata ed abilitata allo scopo.

### ATTENZIONE

Tutti i prodotti CAB sono coperti da polizza assicurativa che risponde di eventuali danni a cose o persone causati da difetti di fabbricazione, richiede però la marcatura CE della "macchina" e l'utilizzo di componenti originali CAB.

### SAFETY RULES

- Do not stand in the movement area of the gate.
- Do not let children play with controls and near the gate.
- Should operating faults occur, do not attempt to repair the fault but call a qualified technician.

### MANUAL AND EMERGENCY GATE OPERATION

If there is a power failure or malfunction the wings can be moved by hand as follows:

#### Models with hydraulic lock (HD.3524E AC - HD.5024E AC):

- Use the special key supplied with the operator to open the protective cover of the release mechanisms (Fig.1).
- Turn the knob anticlockwise to disengage the automation. (Fig.2)
- The wing can now be opened and closed manually.
- To engage the automation turn the knob clockwise.
- Lock the cover shut.

#### Models without hydraulic lock (HD.3524E - HD.5024E AC):

Since these models are reversible, simply open the electric lock and the wing can be moved manually.

Slowly push the wing by its outer end, accompanying it all the way to the gate stop. The movement may be made easier by slackening the release knob.

### MAINTENANCE

- Every month check the good operation of the emergency manual release.
- It is mandatory not to carry out extraordinary maintenance or repairs as accidents may be caused.
- These operations must be carried out by qualified personnel only.
- Periodically check safety components and any other parts of the system

### WASTE DISPOSAL

If the product must be dismantled, it must be disposed according to regulations in force regarding the differentiated waste disposal and the recycling of components (metals, plastics, electric cables, etc.). For this operation it is advisable to call your installer or a specialised company.

### WARNING

All CAB products are covered by insurance policy for any possible damages to objects and persons caused by construction faults under condition that the entire system be marked CE and only CAB parts be used.

Aprire lo sportellino per accedere alla manopola di sblocco  
*Open the protective cover to access the release knob*

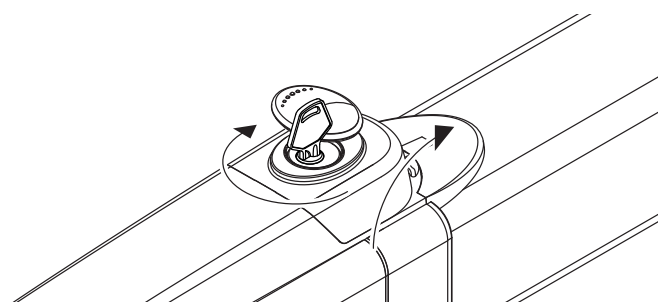

- 1: Ruotare in senso antiorario per sbloccare l'automazione e muovere manualmente l'anta
  - 2: Ruotare in senso orario per ripristinare il movimento automatico
- 1: Turn anticlockwise to disengage the operator and move the wing manually  
2: Turn clockwise to engage the operator

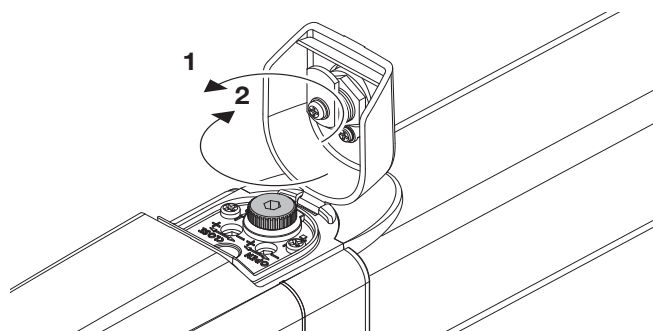

## Dichiarazione di Conformità UE (DoC)

Nome del produttore: **Automatismi CAB Srl**  
Indirizzo: **Via della Tecnica, 10 (z.i.) - 36010 Velo d'Astico (VI) - Italia**  
Persona autorizzata a costruire la documentazione tecnica: **Automatismi CAB Srl**  
Tipo di prodotto: **Attuatore oleodinamico 24Vdc per cancelli a battente**  
Modello/Tipo: **HD.35 - HD.35C - HD.35AC - HD.40L - HD.50 - HD.50AC**  
Accessori: **N/A**

Il sottoscritto Luigi Benincà, in qualità di Responsabile Legale, dichiara sotto la propria responsabilità che il prodotto sopraindicato risulta conforme alle disposizioni imposte dalle seguenti direttive:

**Direttiva 2014/30/UE** del Parlamento europeo e del Consiglio, del 26 febbraio 2014, concernente l'armonizzazione delle legislazioni degli Stati membri relative alla compatibilità elettromagnetica (**EMCD**), secondo le seguenti norme armonizzate: EN 61000-6-2:2005, EN 61000-6-3:2007.

**Direttiva 2011/65/UE** del Parlamento europeo e del Consiglio, dell'8 giugno 2011, sulla restrizione dell'uso di determinate sostanze pericolose nelle apparecchiature elettriche ed elettroniche (**RoHS**), secondo le seguenti norme armonizzate:

EN 50581:2012

Benincà Luigi, Responsabile legale.  
Velo d'Astico, 27/07/2017.

Il Certificato di Conformità di questo documento corrisponde all'ultima revisione disponibile al momento della stampa e può risultare differente per esigenze editoriali dall'originale disponibile presso il produttore.

Il Certificato di Conformità più completo e recente può essere richiesto presso:  
Automatismi CAB Srl - Velo d'Astico VI - Italy.

## UE Declaration of Conformity (DoC)

Manufacturer's name: **Automatismi CAB Srl**  
Address: **Via della Tecnica, 10 (z.i.) - 36010 Velo d'Astico (VI) - Italia**  
Person authorised to draft the technical documentation: **Automatismi CAB Srl**  
Product type: **Hydraulic actuator 24Vdc for swing gates**  
Model/type: **HD.35 - HD.35C - HD.35AC - HD.40L - HD.50 - HD.50AC**  
Accessories: **N/A**

The undersigned Luigi Benincà, as the Legal Officer, declares under his liability that the aforementioned product complies with the provisions established by the following directives:

**Directive 2014/30/UE OF THE EUROPEAN PARLIAMENT AND OF THE COUNCIL** of 26 February 2014, on the harmonisation of the laws of Member States relating to electromagnetic compatibility (**EMCD**), according to the following harmonised regulations:

EN 61000-6-2:2005, EN 61000-6-3:2007 + A1:2011.

**Directive 2011/65/EU** of the European Parliament and Council, dated 8 June 2011, on the restricted use of certain hazardous substances in electrical and electronic devices (**RoHS**), according to the following standards:

EN 50581:2012

Benincà Luigi, Legal Officer.  
Velo d'Astico, 27/07/2017.

The certificate of conformity in this document corresponds to the last review available at the time of printing and could differ for editorial requirements from the original available from the manufacturer.

The most recent and complete certificate of conformity can be requested from:  
Automatismi CAB Srl - Velo d'Astico VI - ITALY.

## EG-Konformitätserklärung (DoC)

Name des Herstellers: **Automatismi CAB Srl**  
Adresse: **Via della Tecnica, 10 (z.i.) - 36010 Velo d'Astico (VI) - Italia**  
Zur Erstellung der technischen Dokumentation berechtigte Person: **Automatismi CAB Srl**  
Produkttypus: **Hydraulischer 24Vdc-Antrieb für Drehtoranlagen**  
Modell/Typus: **HD.35 - HD.35C - HD.35AC - HD.40L - HD.50 - HD.50AC**  
Zubehör: **N/A**

Der Unterzeichnete Luigi Benincà, in seiner Eigenschaft als Rechtsvertreter, erklärt eigenverantwortlich, dass das oben angegebene Produkt den durch die folgenden Richtlinien vorgegebene Bestimmungen entspricht:

**Richtlinie 2014/30/UE** DES EUROPÄISCHEN PARLAMENTES UND DES RATES vom 26. Februar 2014 zur Angleichung der Rechtsvorschriften der Mitgliedstaaten über die elektromagnetische Verträglichkeit (**EMCD**), gemäß nachstehenden Normen:

EN 61000-6-2:2005, EN 61000-6-3:2007 + A1:2011.

**Richtlinie 2011/65/EU** des Europäischen Parlaments und des Rates vom 8. Juni 2011 zur Beschränkung der Verwendung bestimmter gefährlicher Stoffe in Elektro- und Elektronikgeräten (**RoHS**), gemäß den folgenden harmonisierten Normen:

EN 50581:2012

Benincà Luigi, Rechtsvertreter.  
Velo d'Astico, 27/07/2017.

Die in diesem Dokument vorliegende Konformitätserklärung entspricht der neuesten zum Druckzeitpunkt erhältlichen Revision und könnte aufgrund von verlegerischen Gründen vom beim Hersteller erhältlichen Original abweichen.

Die neueste und vollständigste Konformitätserklärung kann bei folgender Adresse angefordert werden: Automatismi CAB Srl - Vel d'Astico VI - ITALY.

## Déclaration CE de conformité (DoC)

Nom du producteur : **Automatismi CAB Srl**  
Adresse : **Via della Tecnica, 10 (z.i.) - 36010 Velo d'Astico (VI) - Italia**  
Personne autorisée à construire la documentation technique : **Automatismi CAB Srl**  
Type de produit : **Actionneur oléodynamique 24Vdc pour portails battants**  
Modèle/Type: **HD.35 - HD.35C - HD.35AC - HD.40L - HD.50 - HD.50AC**  
Accessoires : **N/A**

Le soussigné Luigi Benincà, en sa qualité de Représentant Légal, déclare sous sa propre responsabilité que le produit indiqué ci-dessus est conforme aux dispositions imposées par les directives suivantes:

**Directive 2014/30/UE** DU PARLEMENT EUROPÉEN ET DU CONSEIL du 26 février 2014 concernant le rapprochement des législations des États membres relatives à la compatibilité électromagnétique (**EMCD**), selon les suivantes normes harmonisées:

EN 61000-6-2:2005, EN 61000-6-3:2007 + A1:2011.

**Directive 2011/65/UE** du Parlement européen et du Conseil, du 8 juin 2011, sur la restriction à l'usage de substances dangereuses déterminées dans les appareillages électriques et électroniques (**RoHS**), selon les normes harmonisées suivantes :

EN 50581:2012

Benincà Luigi, Représentant Légal.  
Velo d'Astico, 27/07/2017.

Le certificat de conformité présent dans ce document correspond à la dernière révision disponible au moment de l'impression et pourrait différer pour des exigences éditoriales de l'original disponible chez le constructeur.

Le certificat de conformité le plus récent et complet peut être demandé à :  
Automatismi CAB Srl - Velo d'Astico VI - ITALIE.

## Declaración CE de conformidad (DoC)

Nombre del productor: **Automatismi CAB Srl**  
Dirección: **Via della Tecnica, 10 (z.i.) - 36010 Velo d'Astico (VI) - Italia**  
Persona autorizada a producir la documentación técnica: **Automatismi CAB Srl**  
Tipo de producto: **Mando oleodinámico 24Vdc para portones batientes**  
Modelo/Tipo: **HD.35 - HD.35C - HD.35AC - HD.40L - HD.50 - HD.50AC**  
Accesorios: **N/A**

El infrascrito Luigi Benincà, en calidad de Representante Legal, declara bajo su responsabilidad que el producto anteriormente mencionado resulta en conformidad con las disposiciones establecidas por las siguientes directivas:

**Directiva 2014/30/UE** del parlamento europeo y del consejo del 26 de febrero de 2014 sobre la aproximación de las legislaciones de los Estados miembros con relación a la compatibilidad electromagnética (**EMCD**), según las siguientes normas armonizadas:

EN 61000-6-2:2005, EN 61000-6-3:2007.

**Directiva 2011/65/UE** del Parlamento europeo e del Consejo, de 8 de junio de 2011, sobre restricciones a la utilización de determinadas sustancias peligrosas en aparatos eléctricos y electrónicos (**RoHS**), según las normas siguientes armonizadas:

EN 50581:2012

Benincà Luigi, Representante Legal.  
Velo d'Astico, 27/07/2017.

El certificado de conformidad presente en este documento corresponde a la última revisión disponible en el momento de la impresión y podría diferir por exigencias editoriales del original disponible en la sede del fabricante.

El certificado de conformidad más reciente y completo se puede solicitar a:  
Automatismi CAB Srl - Velo d'Astico VI - ITALY.

## Deklaracja zgodności CE (DoC)

Nazwa producenta: **Automatismi Benincà SpA**  
Adres: **Via Capitello, 45 - 36066 Sandrigo (VI) - Italia**  
Osoba upoważniona do stworzenia dokumentacji technicznej: **Automatismi CAB Srl**  
Rodzaj produktu: **Napęd oleodynamiczny dla bram skrzydłowe**  
Model/Typ: **HD.35 - HD.35C - HD.35AC - HD.40L - HD.50 - HD.50AC**  
Akcesoria: **N/A**

Niżej podpisany/a Luigi Benincà, jako Przedstawiciel prawny, deklaruje na własną odpowiedzialność, że wskazany produkt jest zgodny z rozporządzeniami następujących dyrektyw:

**Dyrektywa 2014/30/WE** rady I parlamentu europejskiego z dnia 26 lutego 2014r. w sprawie zbliżenia ustawodawstwa państw członkowskich w zakresie kompatybilności elektromagnetycznej (**EMCD**), zgodnie z następującymi normami zharmonizowanymi:

EN 61000-6-2:2005, EN 61000-6-3:2007 + A1:2011.

**Dyrektywa 2011/65/WE** Parlamentu Europejskiego i Rady z 8 czerwca 2011 r. w sprawie ograniczenia stosowania niektórych niebezpiecznych substancji w sprzęcie elektrycznym i elektronicznym (**RoHS**), zgodnie z poniższymi normami zharmonizowanymi:

EN 50581:2012

Benincà Luigi, Przedstawiciel prawny.  
Velo d'Astico, 27/07/2017.

Certyfikat zgodności znajdujący się w niniejszym dokumencie odpowiada ostatniej aktualizacji dostępnej w momencie wydruku i może się różnić ze względów wydawniczych od oryginału dostępnego u producenta.

Najbardziej aktualny i kompletny certyfikat zgodności można się po niego zwrócić do:  
Automatismi CAB Srl - Velo d'Astico VI - WŁOCHY.

