

RISE

Rising
Bollards
Evolution

VIGILANT 800/I

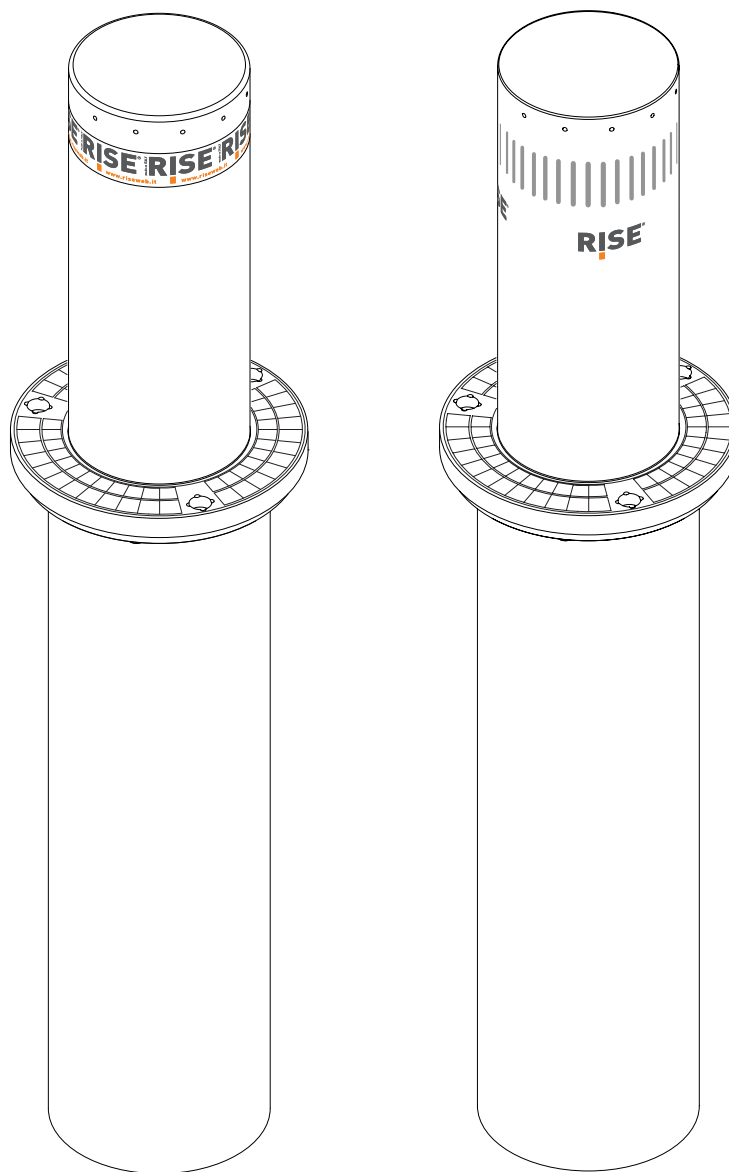

Manuale di installazione
Installation manual
Installationsanleitung
Manuel d'installation
Manual de instalación

- I** Dissuasore di sosta e passaggio
- GB** Parking and passage rising bollard
- D** Poller gegen unrechtmäßiges Parken und Durchfahren
- F** Borne escamotable anti-stationnement et anti-accès
- E** Disuasor de tránsito de aparcamiento y de paso

Made in Italy

Brevettato
Patented



The undersigned Mr. Luigi Benincà, legal representative of the company **Rise S.r.l.** - Via del Capitello, 42 - 36035 Marano Vicentino (VI) – in the capacity of manufacturer declares that the product:

VIGILANT 800/I

complies in all its components with Directives:

- EMC Directive 2004/108/EC
- Low Voltage Directive 2006/95/EC

as per checks carried out by: ECO Certificazioni S.p.A., via Mengolina, 33 - 48018 Faenza (RA)

Marano Vicentino, 30/11/10

The legal representative

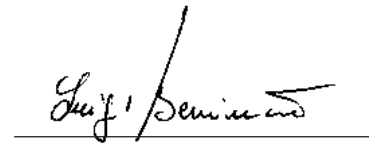

Overall Dimensions

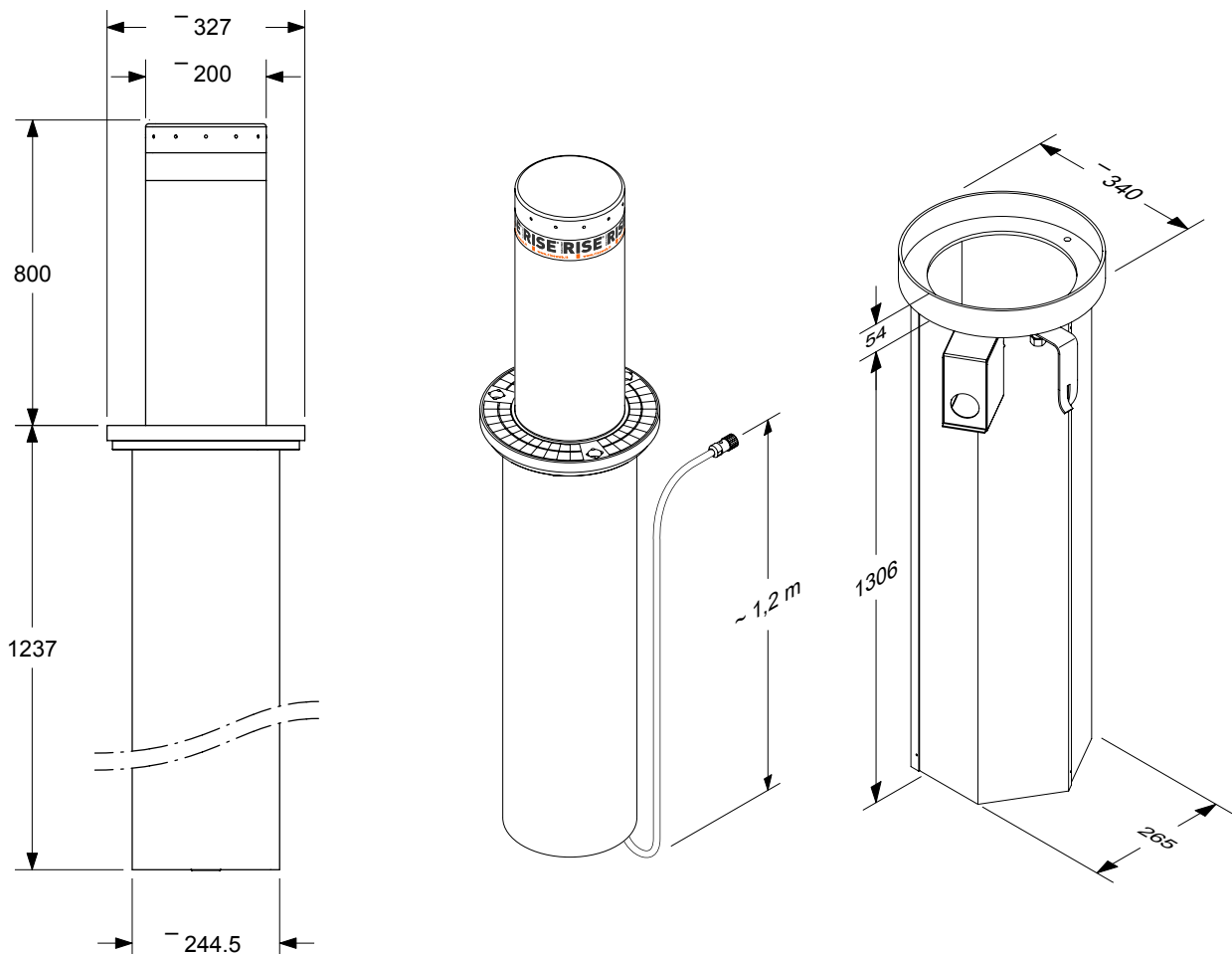

We thank you for having chosen one of our Vigilant model automatic rising bollards.

All articles in the Rise range are the fruit of long experience in the sector of mechanical and electronic automations. This is why today we are able to offer extremely innovative and reliable automatic rising bollards that, thanks to their performance, efficiency and durability, fully satisfy the final customer's requirements.

All our products are covered by a two-year warranty.

Furthermore, a product Civil Liability policy stipulated with a leading insurance company covers any damage to things or persons caused by manufacturing defects.

General information

The Vigilant 800/I automatic rising bollard, with its high resistance to impact and elegant design, is suitable for installation in public or commercial areas and is particularly indicated for protecting of buildings.

The standard version, manufactured in steel, is painted with electrophoresis painting, a corrosion-proof treatment that guarantees an extremely elevated resistance to the elements and to salty environments.

The bollard is operated with 24Vdc; an amperometric sensor detects any obstacles when rising and inverts the movement immediately. The bollard is fitted with 12 leds that operate in sequence and with a high-visibility reflecting band. The bollard can be easily unlocked in an emergency. In the event of a power cut different functions can be selected: the bollard can remain in raised position or can be unlocked and lowered by keeping the emergency button pressed; automatic lowering in the event of a power cut is also available (accessory). The system can also be fitted with an uninterrupted power supply unit (accessory) that allows the bollard to be used in automatic mode even in the event of a power cut.

The foundation case is manufactured in cataphoresis-painted steel and can easily be assembled on site before installation. If the bollard is not installed immediately, a cover for closing the hole is available.

TECHNICAL DATA

MODEL	VIGILANT 800/I
Power supply	230/250 Va.c. 50/60 Hz
Motor power supply	24 Vdc
Motor power	90 W
Motor absorption (24 Vdc)	7 A
Maximum working frequency	40 cycles/h
Protection level	IP 68
Working temperature	-20°C / +50°C
Lubrication	Permanent grease
Cylinder dimensions	Diameter 200x800 mm - thickness 8 mm (Vigilant 800I: +1,2mm Stainless Steel AISI 316)
Foundation case dimensions	Diameter 330x1358 mm
Impact resistance	11.000 J (without permanent deformation)
Breaking strength	180.000 J
Rising time	7"
Lowering time	5"
Weight	Vigilant 800: 112 kg / Vigilant 800I :120 kg
Finish	Vigilant 800: Black cataphoresis + powder paint / Vigilant 800I: Stainless Steel AISI 316

1 - Place the three side elements vertically as in the image alongside.

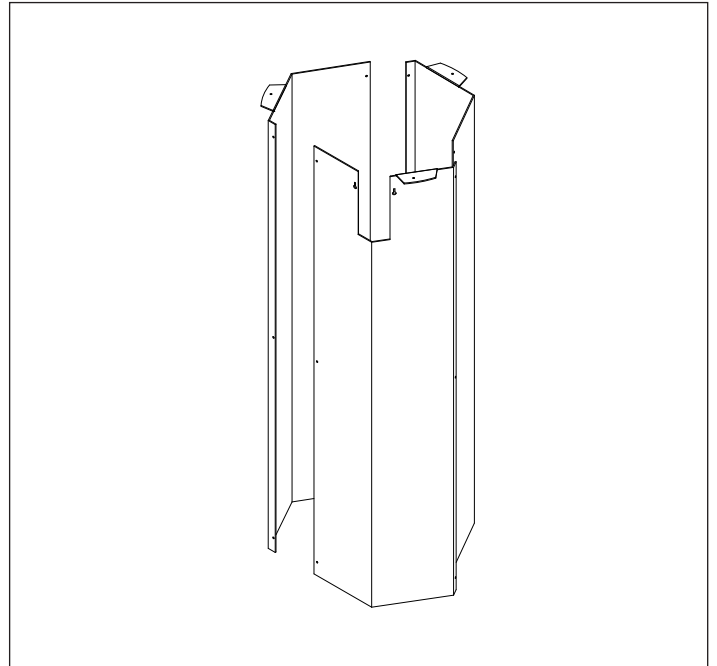

2 - Using the round head screws provided, assemble the hexagonal structure. It is very important to assemble the three elements vertically and on a surface that ensures excellent flatness so as to obtain a reliable support surface for the closing flange. **Attention: The screw head must be placed on the internal side of the foundation case.** See figure alongside.

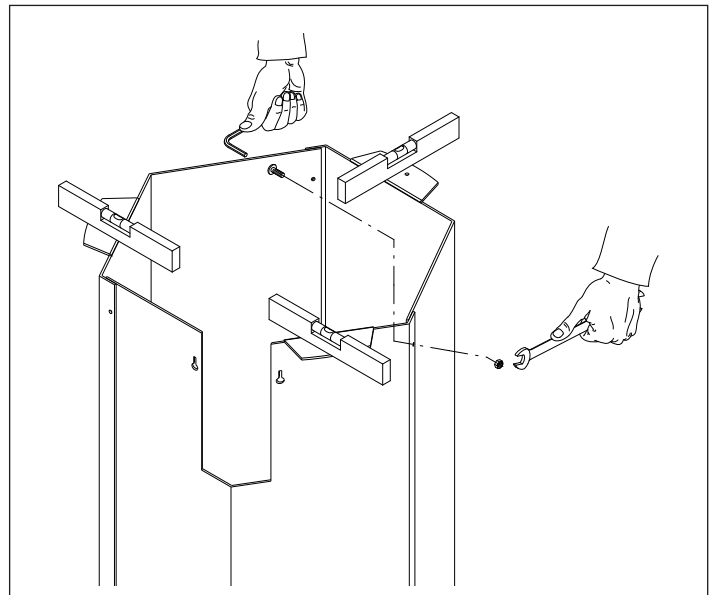

3 - Before fixing the upper flange, insert the metallic protection of the 50 mm diameter corrugated pipe which must be set in the ground to make the subsequent electrical connection with the control unit. See figures alongside.

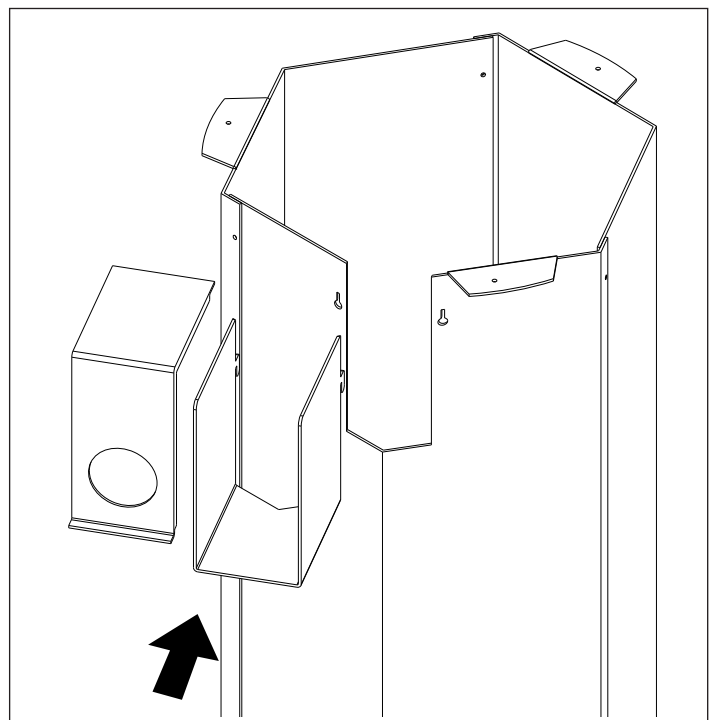

4 - Fix the upper flange using the round head screws provided.

Attention: The screw heads must be placed on the upper part of the flange (inside the case).

This way the foundation case is complete. See figure alongside.

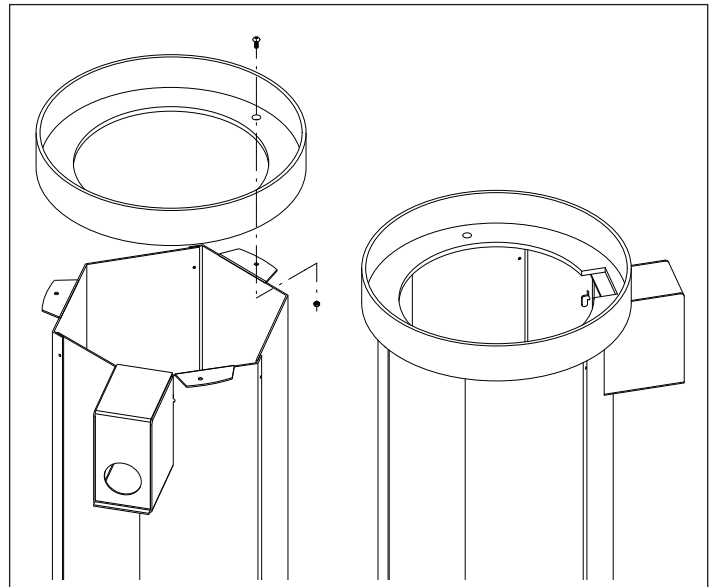

5 - Fit the clamps as in the figure locking them in position with the washer and the M10 hexagonal head screw. Fold them according to the foundation.

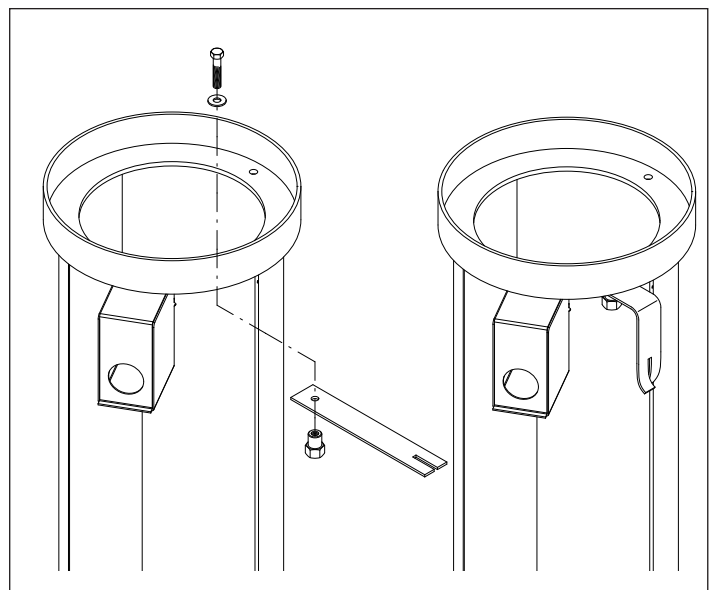

6 - Carry out the excavation in the ground with the measurements indicated in the image alongside and prepare a **suitable draining foundation**. Insert the foundation case in the excavation. **Attention: The case must rest on the bottom of the excavation and must be perfectly vertical - check this by placing a level on the upper flange.**

Important: In order to make inserting the case easier, preparation for the corrugated sheath must be 200mm from the flooring surface, as shown in figure.

Insert the 50 mm diameter corrugated sheath in the case using the metal guide.

The corrugated pipe must enter a maximum of 2/3 cm inside of the metal protection, so that it does not interfere when the bollard is later inserted. Fix the case with cement.

Attention: Make sure, during the cast, that the fixing plug located under the cramp-iron is completely covered by concrete. Using a spirit level, check if the flange plane is horizontal.

TEST FOR DRAINAGE

Dig a hole down to 1400mm and introduce approx 35 lt of water.

Water has to drain out within 30 minutes. In case the water will remain longer into the hole, it is necessary to drain the water out through a pipe connected to a pit with an electric pump.

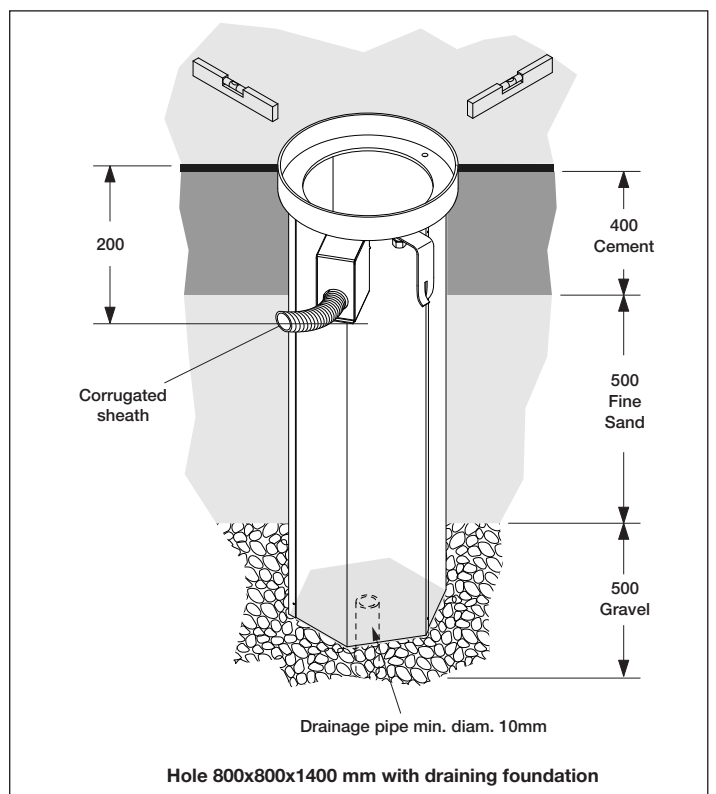

7 - After positioning the case, **make sure that the open recess is covered**, for the entire amount of time that the rising bollard is not inserted, **with covering that is suitable to avoid accidents that may involve persons or property**. A sheet metal cover is available as an option. See figures alongside.

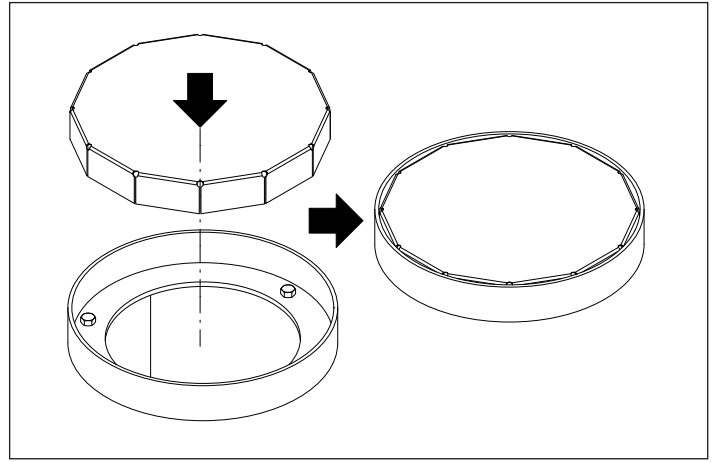

8 - Before inserting the bollard into its housing, remove the previously placed closing or cover making sure that the anchorage housing of the bollard, represented by the grey area, is cleaned carefully. See figures alongside.

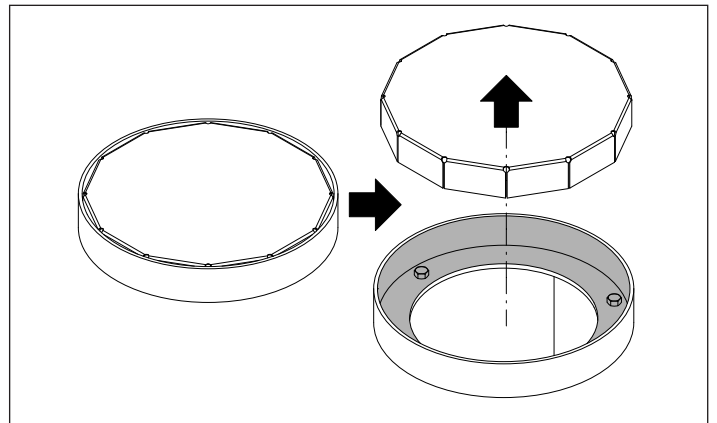

9 -Plan for a junction box in proximity (max 2/3m) of the bollard (Ref. S), where about 1m of extra cable should be left. While inserting the bollard, thanks to this junction box it will be possible to recover/release the cable. When installing multiple bollards, plan on a junction box for each bollard. When laying the conduit, try to keep the path as straight as possible, avoiding sharp corners. See figures alongside.

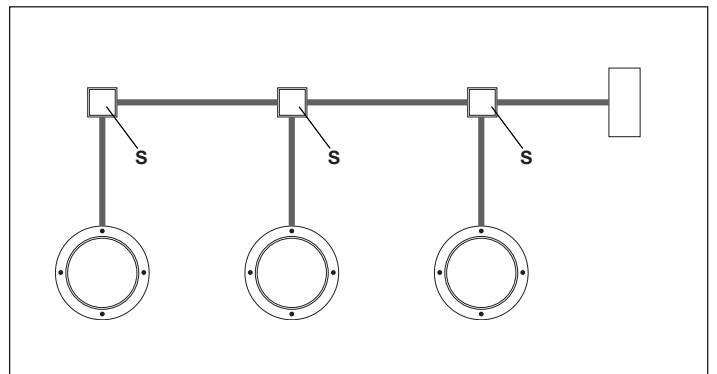

10 -**Attention: The bollard is equipped with a short segment of connection cable equipped with a male IP68 connector. Different size extension cords are available (5 to 25 m), , equipped with a female IP68 connector, for connecting to the control unit.** Bring the two parts of the connector together, aligning the arrow with the circle as shown, then fully screw down the fixing nut.

IMPORTANT: You must close the connector fully and in the correct manner to avoid bending the electrical contacts and to ensure a waterproof seal. Check the connector and the illustrations carefully before proceeding. Do not force the two parts of the connector for any reason.

The connector, when correctly put together, guarantees IP68 protection. The manufacturer cannot guarantee against faults and malfunctions in the event of incorrect connection of the connector.

You are advised to check movement of the connector in the sheathing by simulating the movement of the cable in the bollard, using specific products if necessary.

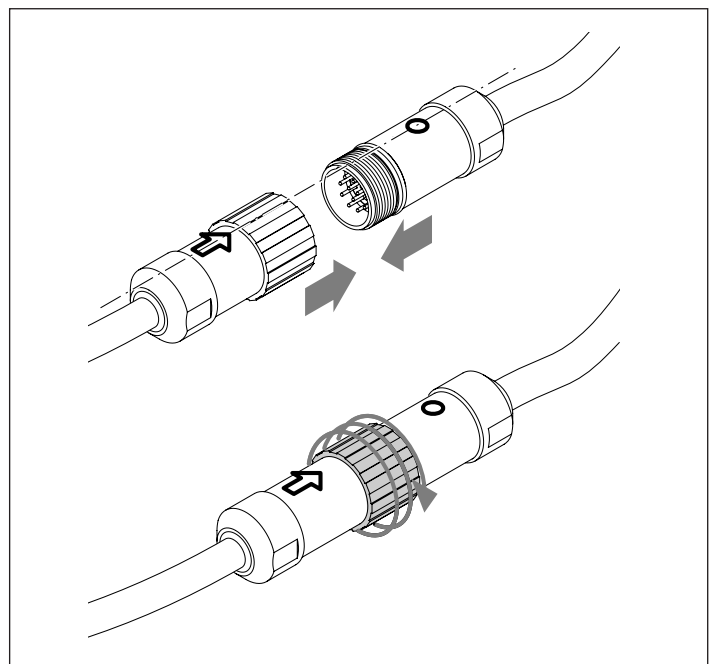

11 - The cable must be recovered while the bollard comes near the foundation case (ref A).

Important: In this phase the connector must be free to slide inside of the corrugated sheath. For this reason is it necessary for the segment between the bollard and the junction box to be connected by a sheath with a diameter of 50 mm, correctly placed, without joints or cross section reductions.

The cable must be gradually released while the bollard descends in the case, (Ref. B)

Once the insertion has been completed, the connector must be in proximity of the metal protection (ref C).

Pay attention to the electrical cable, it must be free inside the case housing and it must not be crushed.

See figures alongside.

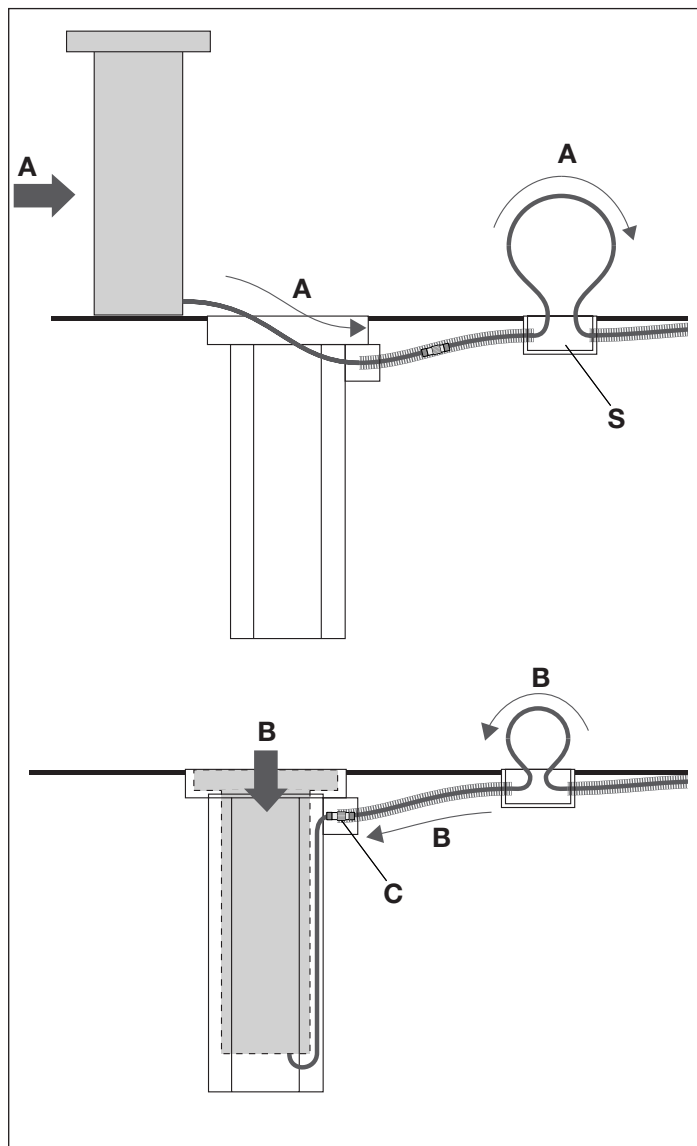

12 - Use three eyebolts with M16 studs to lift the bollard.
See figures alongside.

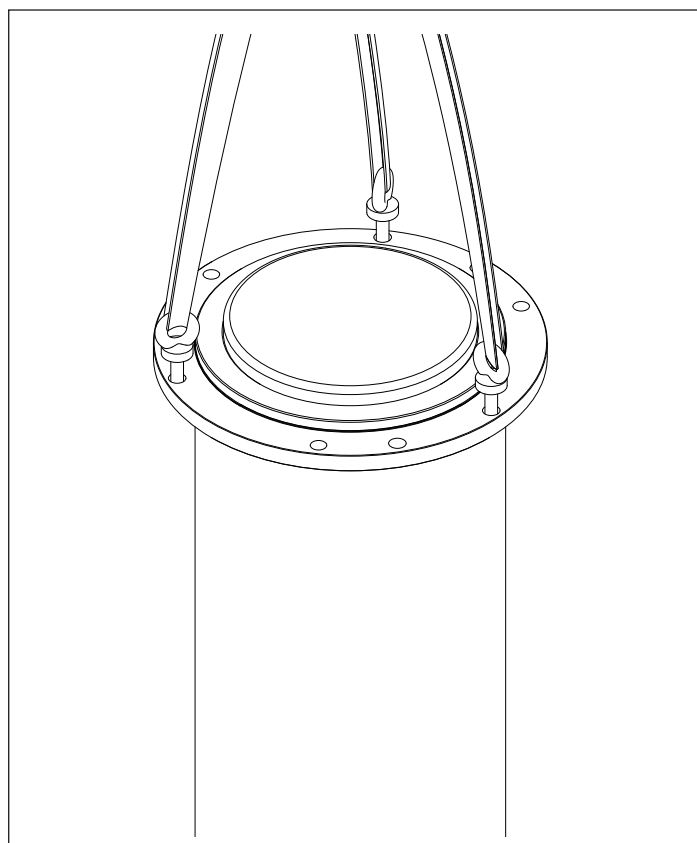

13 - After positioning the bollard inside the case, remove the lifting eye-bolts and, using the same holes, position the blocks on the pipe guide ring.

The blocks are necessary in order to lift the bollard without the treadable flange.

Insert the M10x40 stainless steel screws partially with the relevant washers into the three holes Ø13, without screwing them completely, in order to regulate the planarity of the bollard through the adjustable supports.

Connect the bollard to the control unit and then lift it electrically. Refer to instructions supplied with the control unit.

With the bollard completely lifted, adjust its level. Completing this adjustment with the bollard lifted makes it possible to verify, even visually, that the cylinder is perfectly vertical, a necessary condition for the automation to operate properly.

See figure alongside.

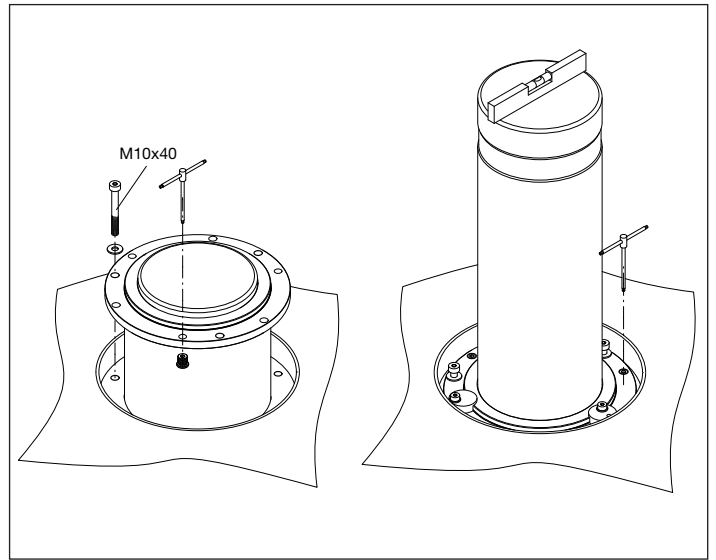

14 - Verify that the distance between the bollard flange and the upper edge of the case/flooring is equal to 23-24 mm.

By respecting this distance the treadable flange will be slightly raised compared (1/2mm) to the flooring, limiting the amount of dirt that may infiltrate the inside of the bollard.

In an effort to reduce possible infiltrations, if the flooring allows it, plan on a slight slope around the foundation case.

See figures alongside.

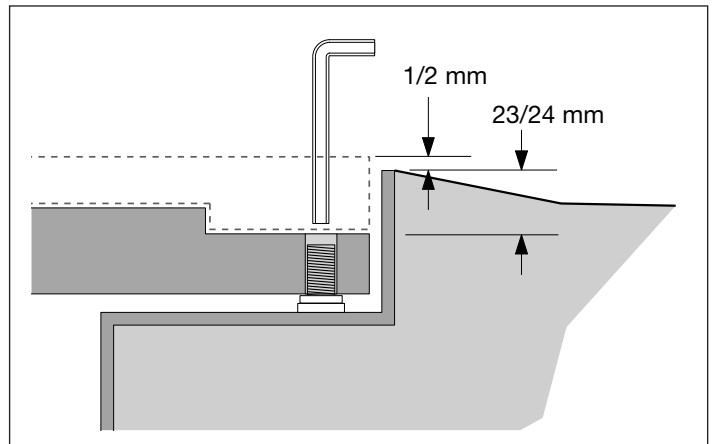

15 - **When the bollard is lowered, take out the blocks on the pipe guide ring and place the treadable flange.**

With the treadable flange check the final level with respect to the external floor.

Insert the washers and the M10x25 TCEI stainless steel screws.

Cover the holes with the rubber caps provided. Carry out the electrical connection carefully following the diagram supplied with the control unit.

See figures alongside.

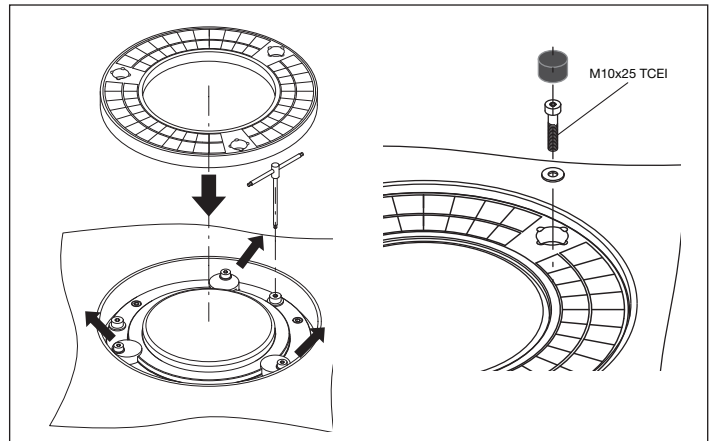

ATTENTION - DANGER



NEVER ACTIVATE THE RISING BOLLARD BEFORE HAVING FIXED THE TREADABLE FLANGE!

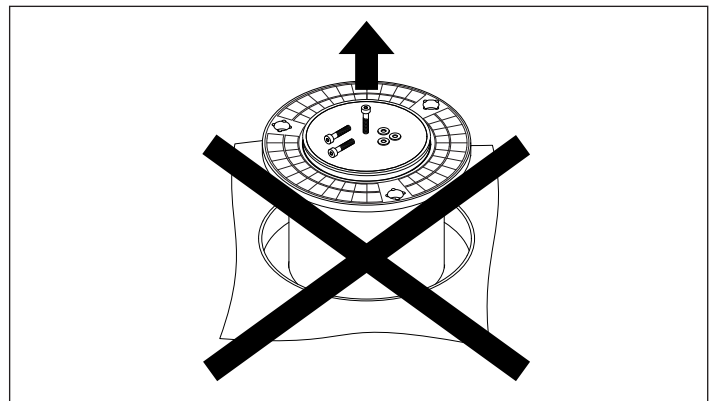

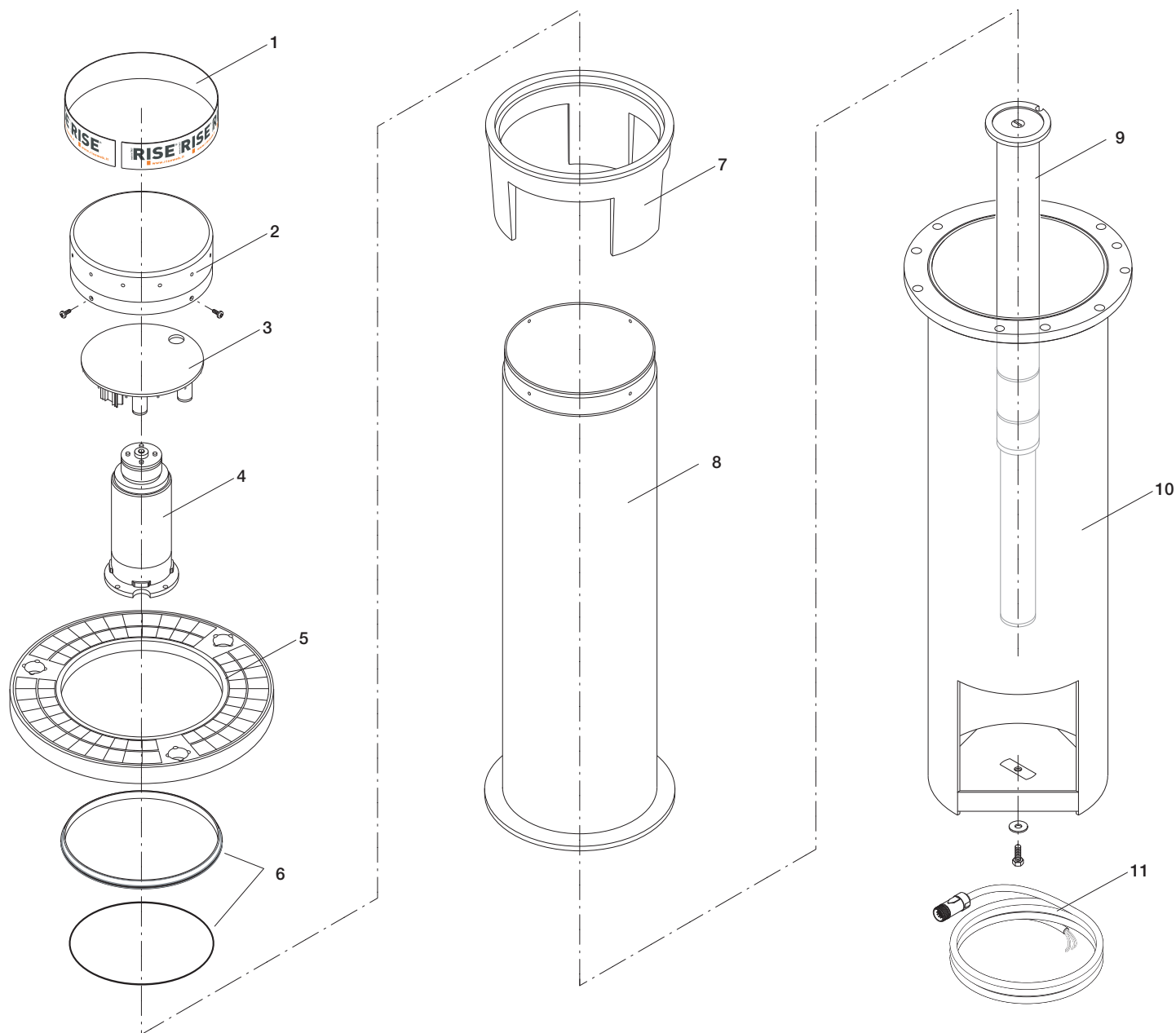

VIGILANT 800

N.	Description	Cod.
1	Retro reflector sticker	R9686001
1b	Retro reflector sticker (800l)	R9686038
2	Cylinder cover	R9686002
3	Control unit	R9686003
4	24Vdc motor with encoder and electronic brake	R9686004
5	Treadable flange	R9686005
6	Flange gasket + O-ring	R9686006
7	Mechanical stop collar	R9686014
8	Mobile cylinder	R9686015
8b	Inox jacket (800l)	R9686035
9	Actuator	R9686016
10	Fixed cylinder	R9686017
11	Connection cable with IP68 connector	R9686018

VIGILANT 800I

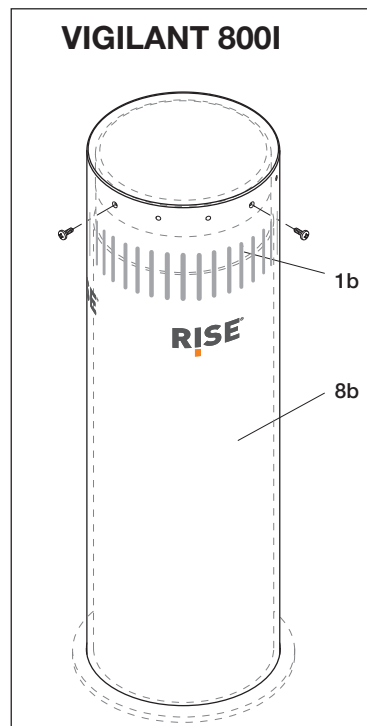

SAFETY STANDARDS

ATTENTION:

Carefully read the instructions manual in all of its parts and keep it in a safe location for any future consultation. Not following the standards and warnings included in the present manual or an incorrect installation may damage persons or property.

- This product has been designed and manufactured exclusively for the use indicated in this documentation. Any non-conforming use may damage the product or be a source of danger for persons and/or property.
- Do not install the product in an explosive atmosphere: the presence of flammable gasses or vapours is a source a serious danger.
- Installation must be completed in observance of current standards.
- For installation in countries outside of the EEC, besides national reference regulations, the above mentioned standards and warnings must be obeyed in order to obtain a suitable level of safety.
- Verify that the system has been earthed according to Good Practice standards and the metal parts must be connected to it.
- For each system, a suitable sign is recommended.
- Do not stand in the movement area of the bollard.
- Do not leave packaging materials (plastic, polystyrene, wood ...) within reach of children because they may be a potential source of danger.
- Do not allow children to play with the commands or in proximity of the bollard.
- In the case of functioning anomalies do not attempt to repair the fault but contact a specialised technician. Only use original RISE Srl accessories.
- Do not modify any components that are part of the RISE system. Any modification, alterations or tampering with the RISE system, or the use of non original RISE accessories, will cause the product warranty to lapse and RISE Srl declines any responsibility with regards to safety and proper system operation.
- The installer must provide the user with all information necessary for system use and maintenance along with manual and emergency manoeuvres. He must deliver them and the user must request the booklet containing warnings and use and maintenance standards.
- The bollard must be completely lowered before transiting through the controlled passage area.
- **Anything that is not specifically planned for in these instructions is not allowed.**

ATTENTION: PRECAUTIONS FOR USE

In case of flooding or significant precipitation that causes obvious drainage problems, avoid using the bollard until normal conditions have been restored.

MANUAL EMERGENCY MANOEUVRE

In the event of a power cut or of malfunction the bollard can be unlocked with the emergency switch fitted close to the control unit. Keep the switch pressed to lower the bollard.

Control units for 2/4 bollards are equipped with ABC clamps that raise or lower the bollard even in case of complete control unit malfunction and without mains power supply.

MAINTENANCE

- Replace the buffer battery in the control unit maximum every 2 years. Dispose of them in compliance with the Standards in force.
- Absolutely avoid attempting to carry out repairs: you could cause accidents; for such operations call a specialised technician.

Maintenance to bollards, control units and the entire system must be completed exclusively by specialised technical personnel. The RISE bollards do not require any special maintenance, periodically checking that the area around the bollard is sufficiently clean and, as needed, the gaskets at the base of the bollard should be replaced. Programmed routine controls of the entire system are recommended only in cases of intense product use in order to ensure correct operation and long product life.

Check the state and efficiency of the control unit and UPS unit batteries at least once a year and, if necessary, have them replaced. The batteries must be replaced at least once every two years. For other instructions regarding product maintenance consult the technical manuals supplied with the bollards and control units.

DISPOSAL

If the bollard is withdrawn from service, the current laws and regulations in force concerning the separate waste disposal and the recycling of the various components (metals, plastics, electric cables etc.) must be respected; it is advisable to contact your installer or a specialised company, authorised for the purpose.

ATTENTION

All RISE products are covered by an insurance policy that answers for any damage to things or persons caused by manufacturing defects.

RISE



Rising
Bollards
Evolution